

4

3

2

1

COVER

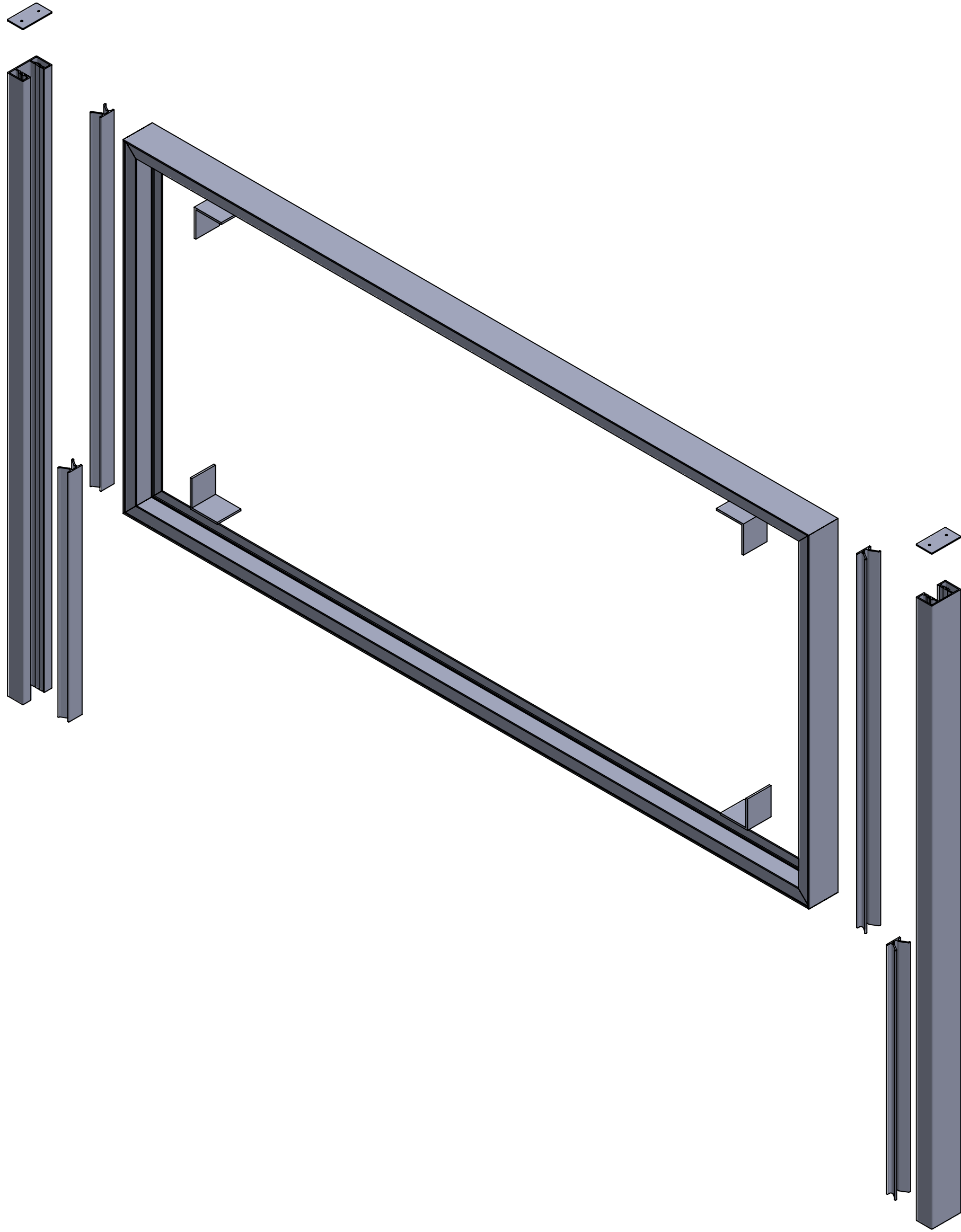

EXPLODED ISO VIEW

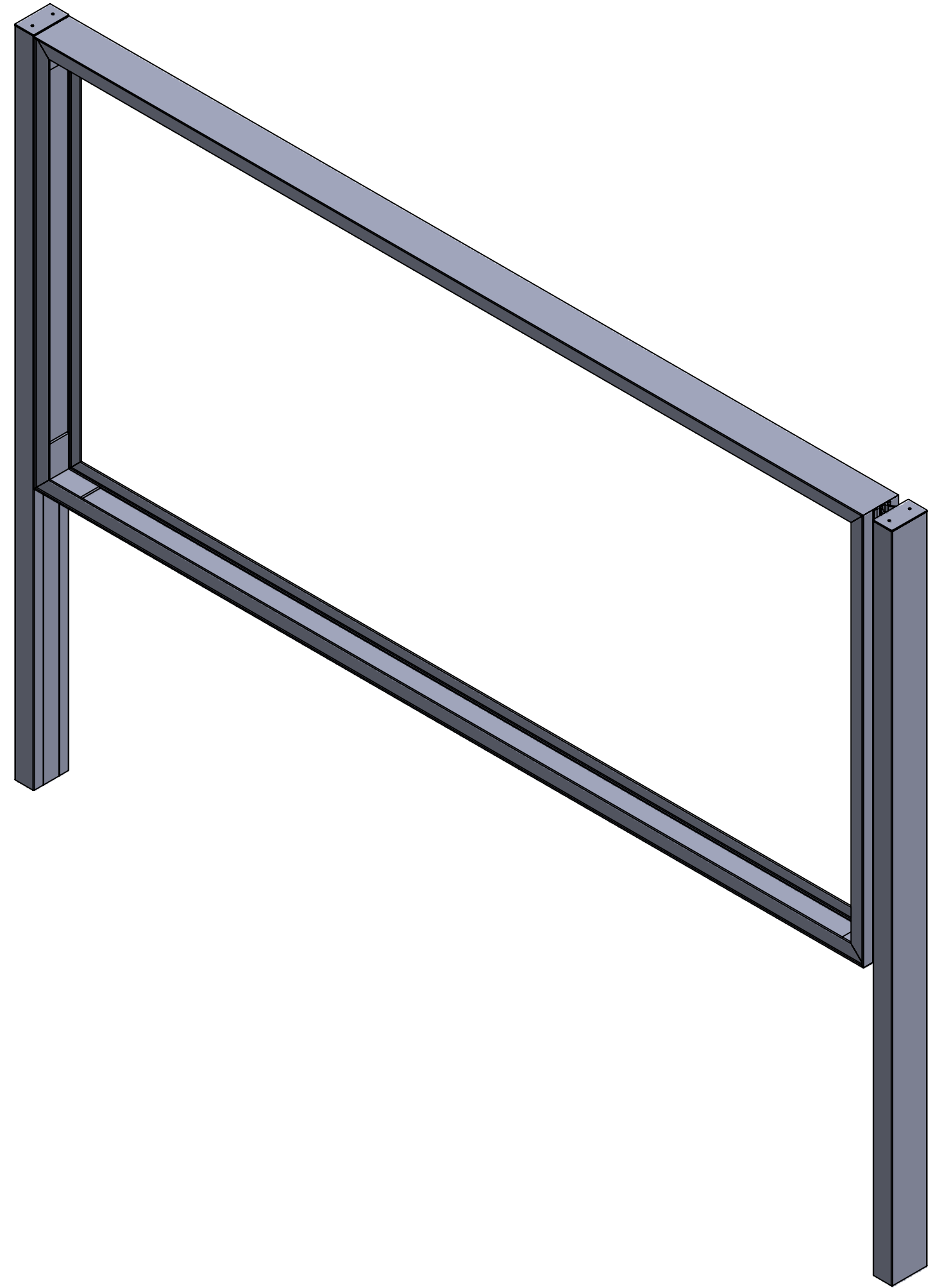

ASSEMBLED ISO VIEW

EXCELLART SIGN PRODUCTS, LLC. 1654 S. LONE ELM RD. OLATHE, KS 66061 (800) 627-9044 SALES@EXCELLART.COM WWW.EXCELLART.COM	UNLESS OTHERWISE SPECIFIED: DIMENSIONS ARE IN INCHES TOLERANCES FRAC = ± 1/32" X.XX = ±0.03 X.XXX = ±0.010 ANGULAR: MACH±1 BEND ±2	ASSEMBLY ID: ESPS-PF-RECDF	
		DESCRIPTION: ESP-POST AND FRAME KIT	
EXCELLART <small>THE INFORMATION CONTAINED IN THIS DRAWING IS THE SOLE PROPERTY OF EXCELLART SIGN PRODUCTS, LLC. ANY REPRODUCTION IN PART OR AS A WHOLE WITHOUT THE WRITTEN PERMISSION OF EXCELLART SIGN PRODUCTS, LLC IS PROHIBITED.</small>	PROPRIETARY AND CONFIDENTIAL	DRAWN BY: EXCELLART	APPROVED BY:
	SIZE C	Weight: 39.259 (lbs) Perimeter Length: (ft) -	REV
	SCALE: 1:8	6/27/2024	SHEET 1 OF 3

4

3

2

1

D

D

C

C

B

B

A

A

4

3

2

1

DIMS

NOTES:

1) Sign Face Perimeter = 18.62 ft

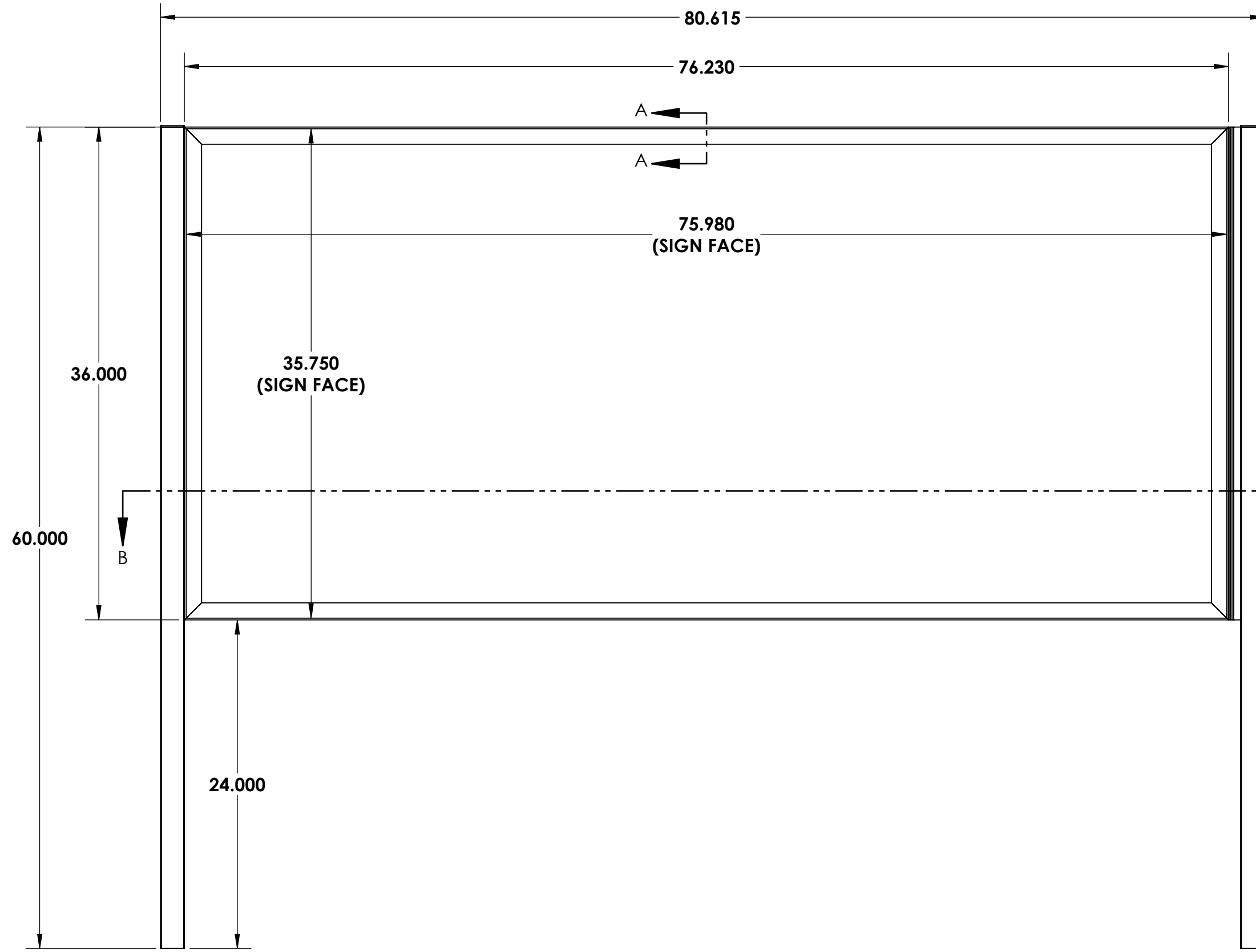

FRONT VIEW

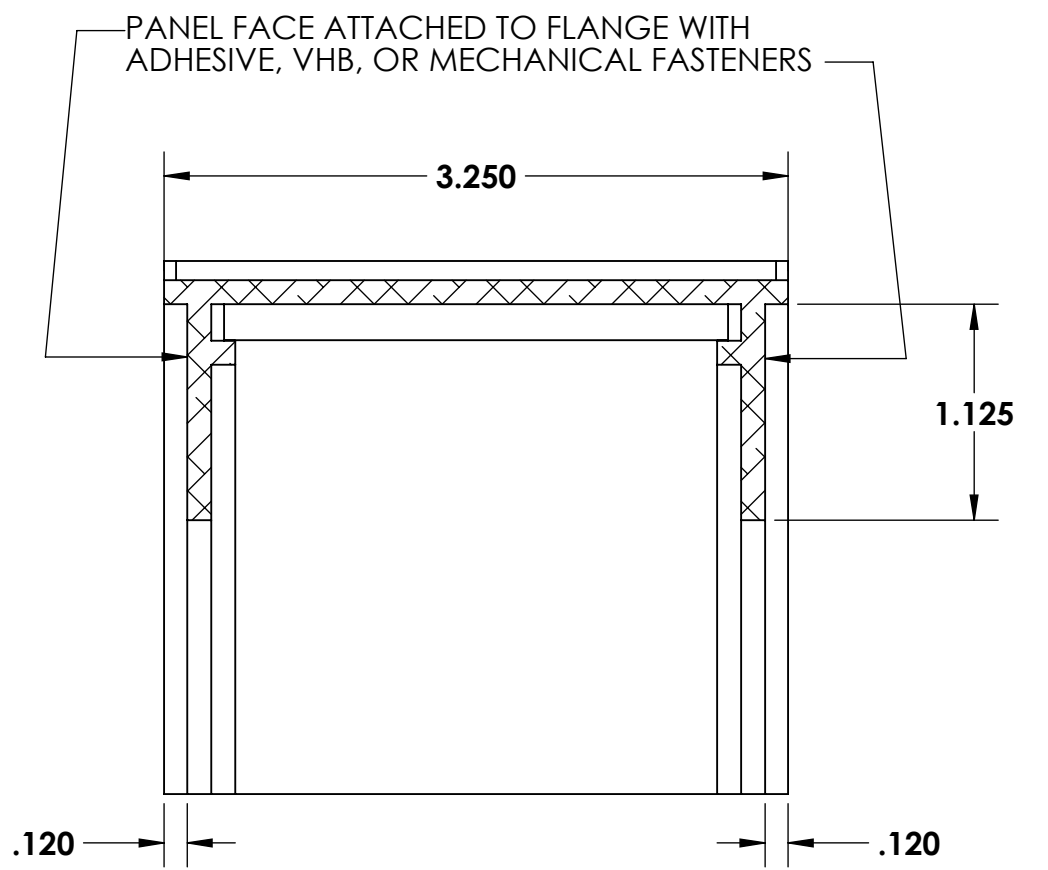

SECTION A-A
SCALE 1 : 1

RECTANGULAR CORNER POST

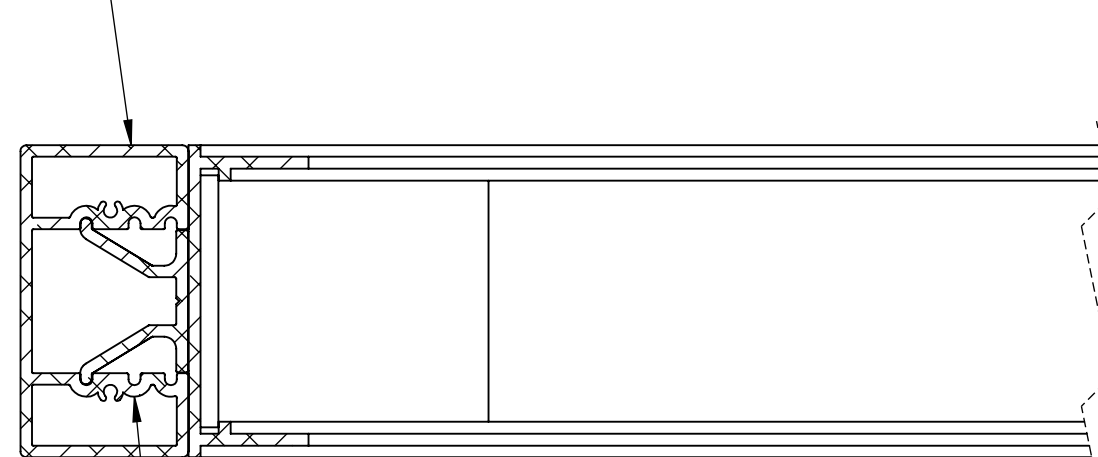

REVEAL CONNECTOR CAN BE SET AT THREE DIFFERENT DEPTHS: FLUSH, 3/8" AND 7/8"

SECTION B-B
SCALE 1 : 2

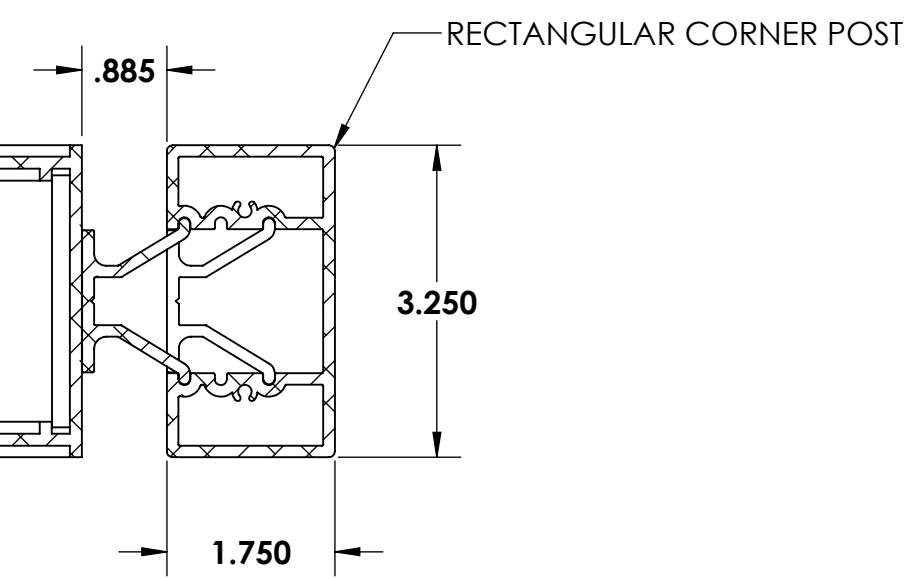

EXCELLART SIGN PRODUCTS, LLC. 1654 S. LONE ELM RD. OLATHE, KS 66061 (800) 627-9044 SALES@EXCELLART.COM WWW.EXCELLART.COM	UNLESS OTHERWISE SPECIFIED: DIMENSIONS ARE IN INCHES TOLERANCES FRAC = ± 1/32" X.XX = ± 0.03 X.XXX = ± 0.010 ANGULAR: MACH ± 1 BEND ± 2	ASSEMBLY ID: ESPS-PF-RECDF	
		DESCRIPTION: ESP-POST AND FRAME KIT	
EXCELLART <small>THE INFORMATION CONTAINED IN THIS DRAWING IS THE SOLE PROPERTY OF EXCELLART SIGN PRODUCTS, LLC. ANY REPRODUCTION IN PART OR AS A WHOLE WITHOUT THE WRITTEN PERMISSION OF EXCELLART SIGN PRODUCTS, LLC IS PROHIBITED.</small>	DRAWN BY: EXCELLART	APPROVED BY:	
	SIZE C	Weight: 39.259 (lbs) Perimeter Length: (ft) -	REV
	SCALE: 1:8	6/27/2024	SHEET 2 OF 3

4

3

2

1

4

3

2

1

BOM

ITEM NO.	PART NUMBER	DESCRIPTION	MATERIAL	QTY.
1	ESP1380302	ESP-3.25 RECTANGULAR POST	6063-T6	2
2	ESP1380303	ESP-3.25 PANEL FRAME	6063-T6	1
3	ESP1380101	ESP-3.25 REVEAL CONNECTOR	6063-T6	2
4	ESP1380101	ESP-3.25 REVEAL CONNECTOR (SHORT)	6063-T6	2
5	ESP1380330	ESP-3.25 RECTANGULAR POST END CAP	5052-H32	2
6	ESP1280614	2 5/8" x 3" x 3" x 3/16" ANGLE	6063-T6	4

NOTES:

- 1) ESP-PF KIT (POST AND FRAME KIT) WITH ESP-3.25 RECTANGULAR POSTS CONSISTS OF QTY (4) ESP-3.25 PANEL FRAME PIECES, QTY (4) CORNER ANGLES, QTY (2) ESP-3.25 RECTANGULAR POSTS, QTY (2) ESP-3.25 REVEAL CONNECTORS, QTY (2) ESP-3.25 REVEAL CONNECTORS (SHORT), AND QTY (2) ESP-3.25 RECTANGULAR POST END CAPS
- 2) ANGLES ARE USED TO GUIDE FRAME PIECES INTO POSITION
- 3) GUSSETS ARE USED TO GUIDE RETAINER PIECES INTO POSITION (IF APPLICABLE)
- 4) HINGED FRAME SECTION AND HINGED RETAINERS SHOWN TO BE ON TOP OF SIGN CABINET (IF APPLICABLE)
- 5) SELF DRILLING SCREWS / RIVETS / LOCK CYLINDERS ETC (BY OTHERS) TO SECURE RETAINERS AS NEEDED
- 6) ANGLES AND GUSSETS TYPICALLY WELDED TO FRAMING (BY OTHERS)
- 7) 6" - 8" CENTER TO CENTER SPACING RECOMMENDED FOR FLEX CLIPS
- 8) PIANO HINGES USED TO ALLOW IDS RETAINERS TO HINGE OPEN (IF APPLICABLE)
- 9) H1 / H1.5 RETAINERS ALLOW SECONDARY FACE TO BE MOUNTED BEHIND PRIMARY FACE
- 10) EXCELLART UL FILE NUMBER: E152309

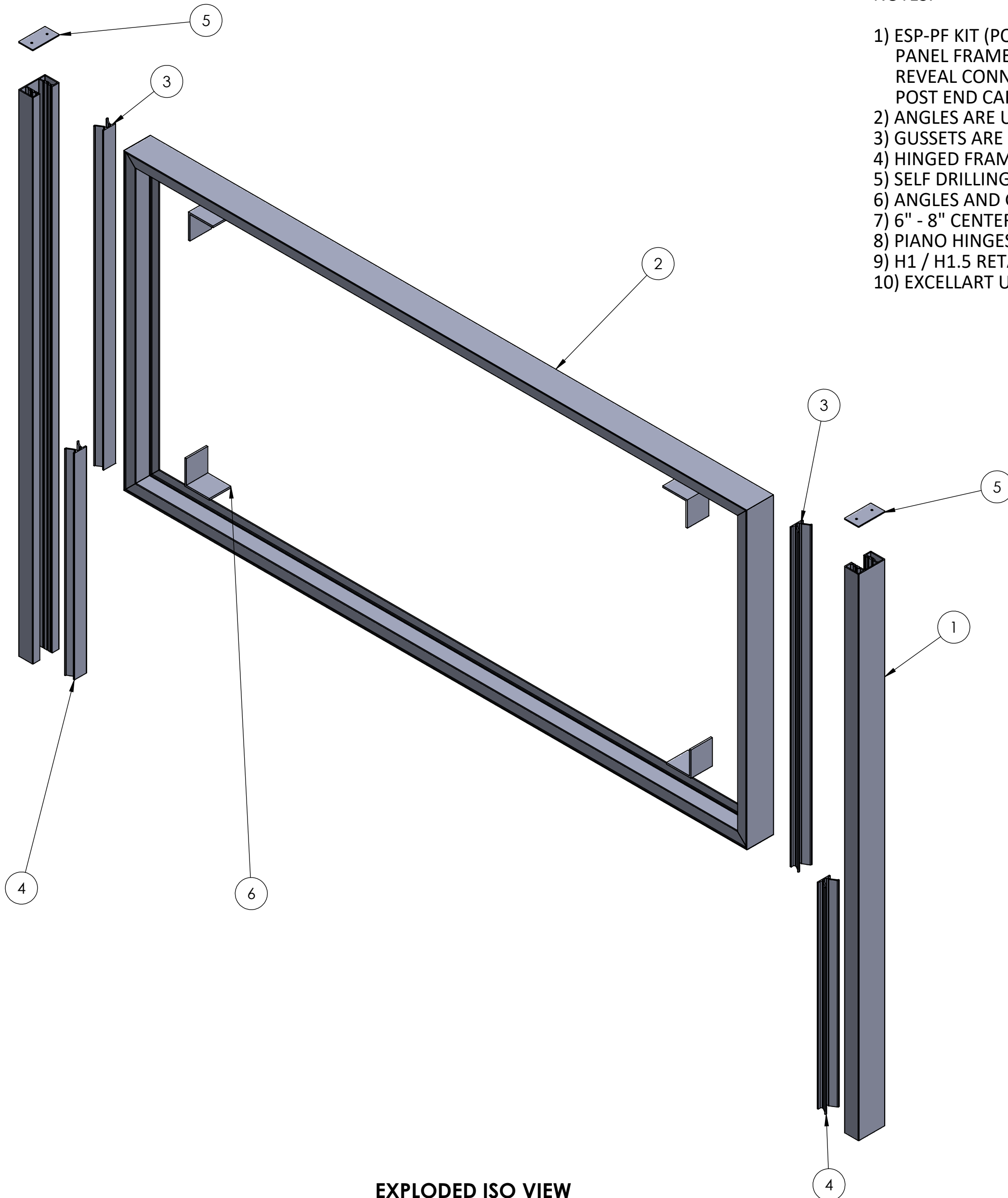

EXPLODED ISO VIEW

EXCELLART SIGN PRODUCTS, LLC. 1654 S. LONE ELM RD. OLATHE, KS 66061 (800) 627-9044 SALES@EXCELLART.COM WWW.EXCELLART.COM	UNLESS OTHERWISE SPECIFIED: DIMENSIONS ARE IN INCHES TOLERANCES FRAC = ±1/32" X.XX = ±0.03 X.XXX = ±0.010 ANGULAR: MACH±1 BEND ±2	ASSEMBLY ID: ESPS-PF-RECDF
	PROPRIETARY AND CONFIDENTIAL THE INFORMATION CONTAINED IN THIS DRAWING IS THE SOLE PROPERTY OF EXCELLART SIGN PRODUCTS, LLC. ANY REPRODUCTION IN PART OR AS A WHOLE WITHOUT THE WRITTEN PERMISSION OF EXCELLART SIGN PRODUCTS, LLC IS PROHIBITED.	DESCRIPTION: ESP-POST AND FRAME KIT
	DRAWN BY: EXCELLART	APPROVED BY:
SIZE C	Weight: 39.259 (lbs) Perimeter Length: (ft) -	REV
SCALE: 1:8	6/27/2024	SHEET 3 OF 3

4

3

2

1