

4

3

2

1

COVER

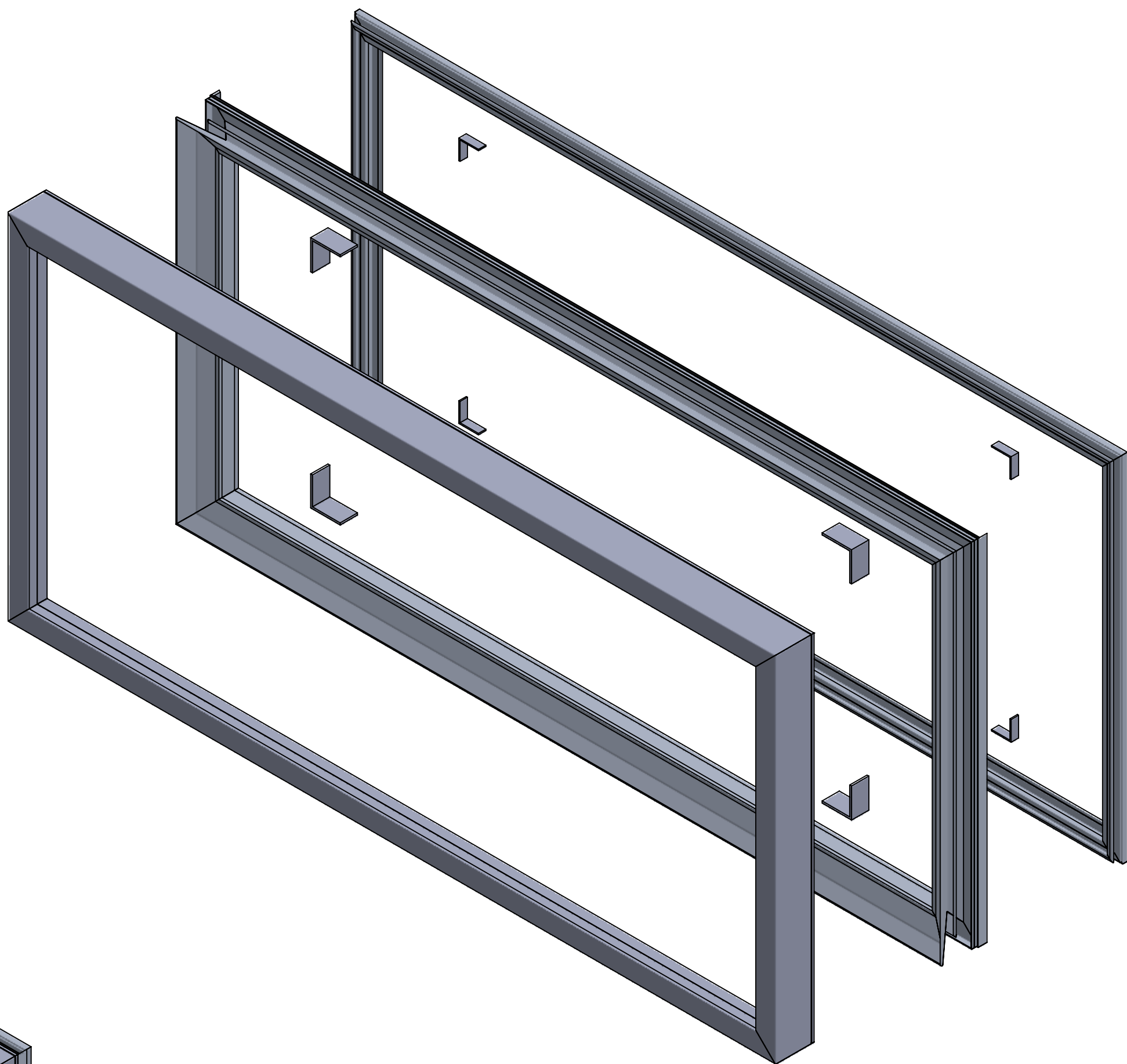
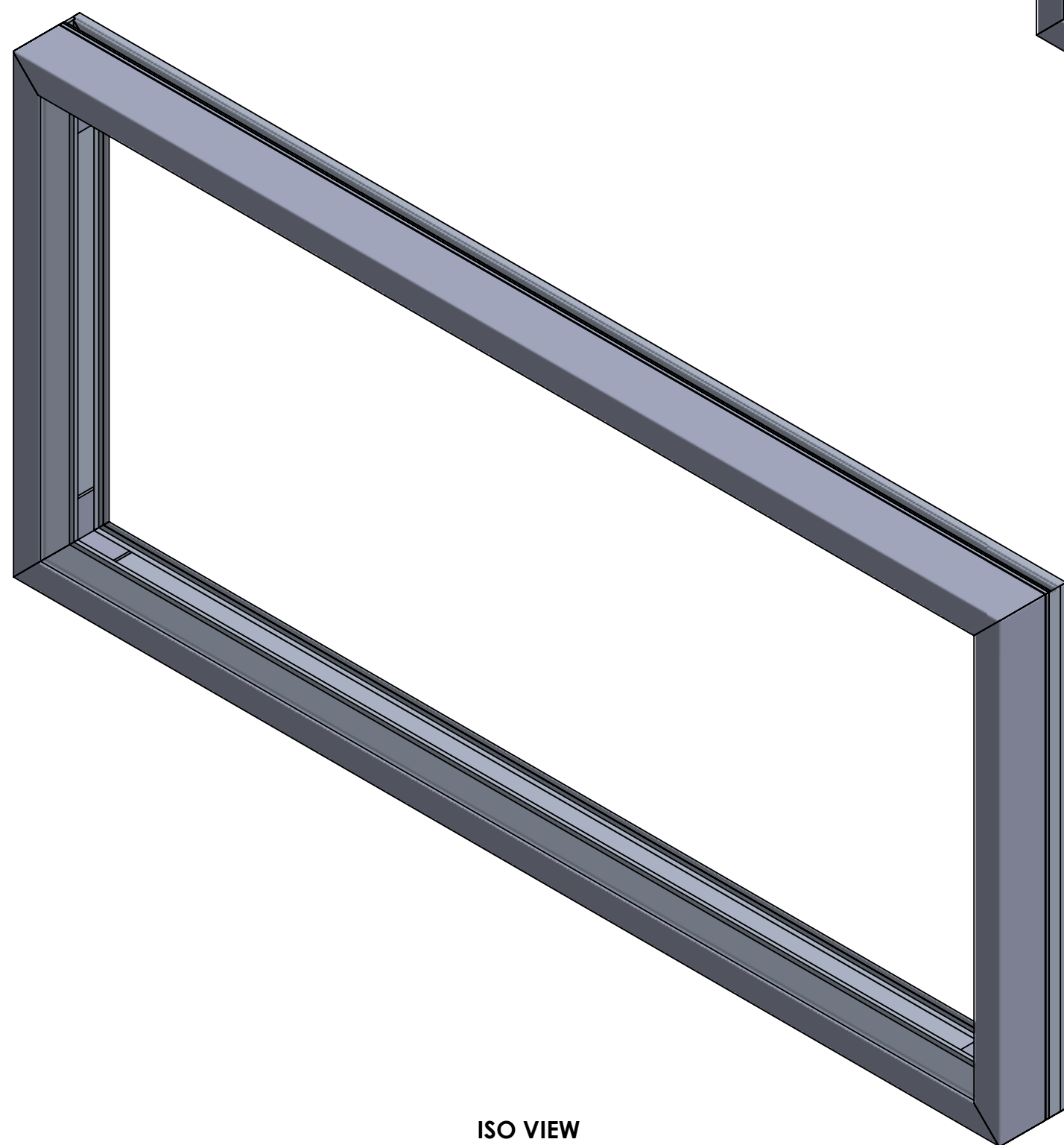

ISO VIEW (EXPLODED)

ISO VIEW

**EXCELLART SIGN PRODUCTS, LLC.**  
 1654 S. LONE ELM RD.  
 OLATHE, KS 66061  
 (800) 627-9044  
 SALES@EXCELLART.COM  
 WWW.EXCELLART.COM



UNLESS OTHERWISE SPECIFIED:  
 DIMENSIONS ARE IN INCHES  
 TOLERANCES:  
 FRAC = ± 1/32"  
 X.XX = ± 0.03  
 X.XXX = ± 0.010  
 ANGULAR: MACH ± 1° BEND ± 2°

**PROPRIETARY AND CONFIDENTIAL**  
 THE INFORMATION CONTAINED IN  
 THIS DRAWING IS THE SOLE  
 PROPERTY OF EXCELLART SIGN  
 PRODUCTS, LLC. ANY  
 REPRODUCTION IN PART OR AS A  
 WHOLE WITHOUT THE WRITTEN  
 PERMISSION OF EXCELLART SIGN  
 PRODUCTS, LLC IS PROHIBITED.

ASSEMBLY ID: <b>ESPH-WM-FLEXSTSF</b>	
DESCRIPTION: <b>ESP-WM HINGED W. FLEX AND STANDARD TRIM</b>	
DRAWN BY: <b>EXCELLART</b>	APPROVED BY:
SIZE <b>C</b>	Weight: <b>47.78</b> (lbs) REV Perimeter Length: <b>19</b> (ft) -
SCALE: 1:8	1/10/2024 SHEET 1 OF 3

4

3

2

1

D

D

C

C

B

B

A

A

4

3

2

1

DIMS

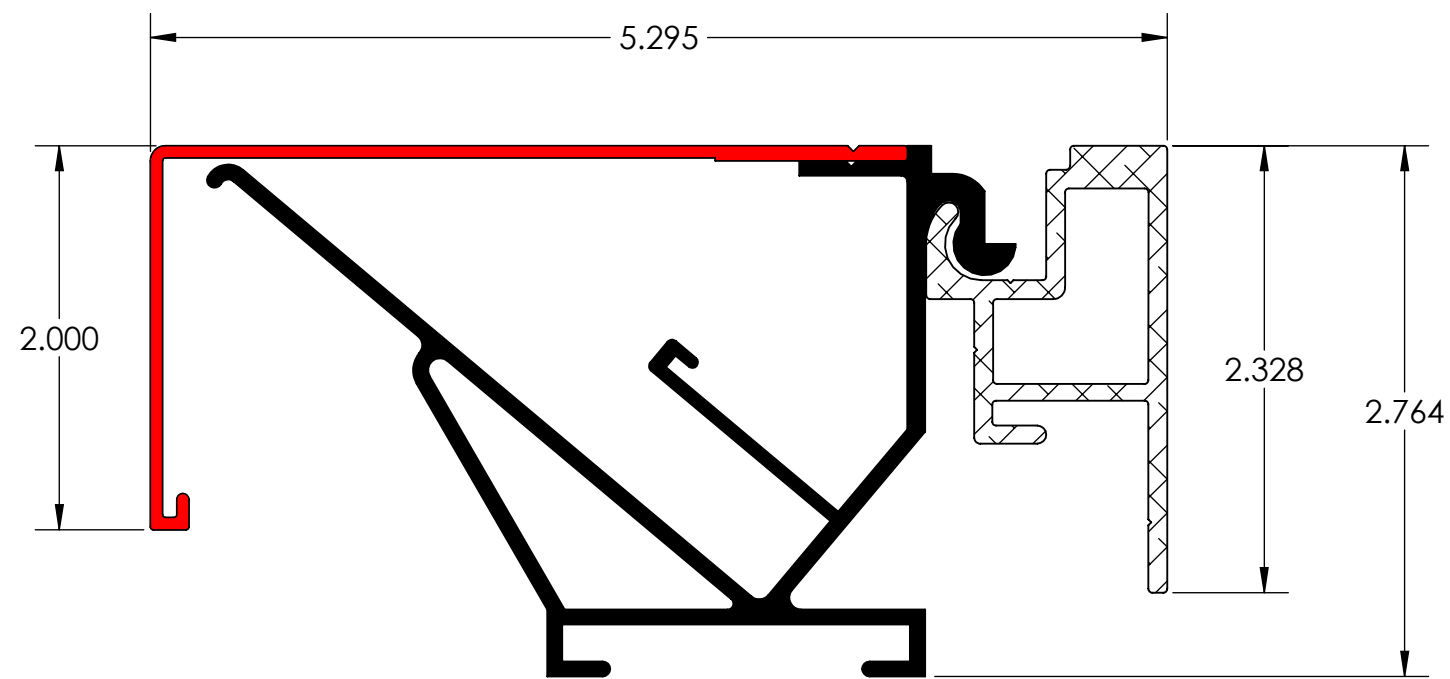
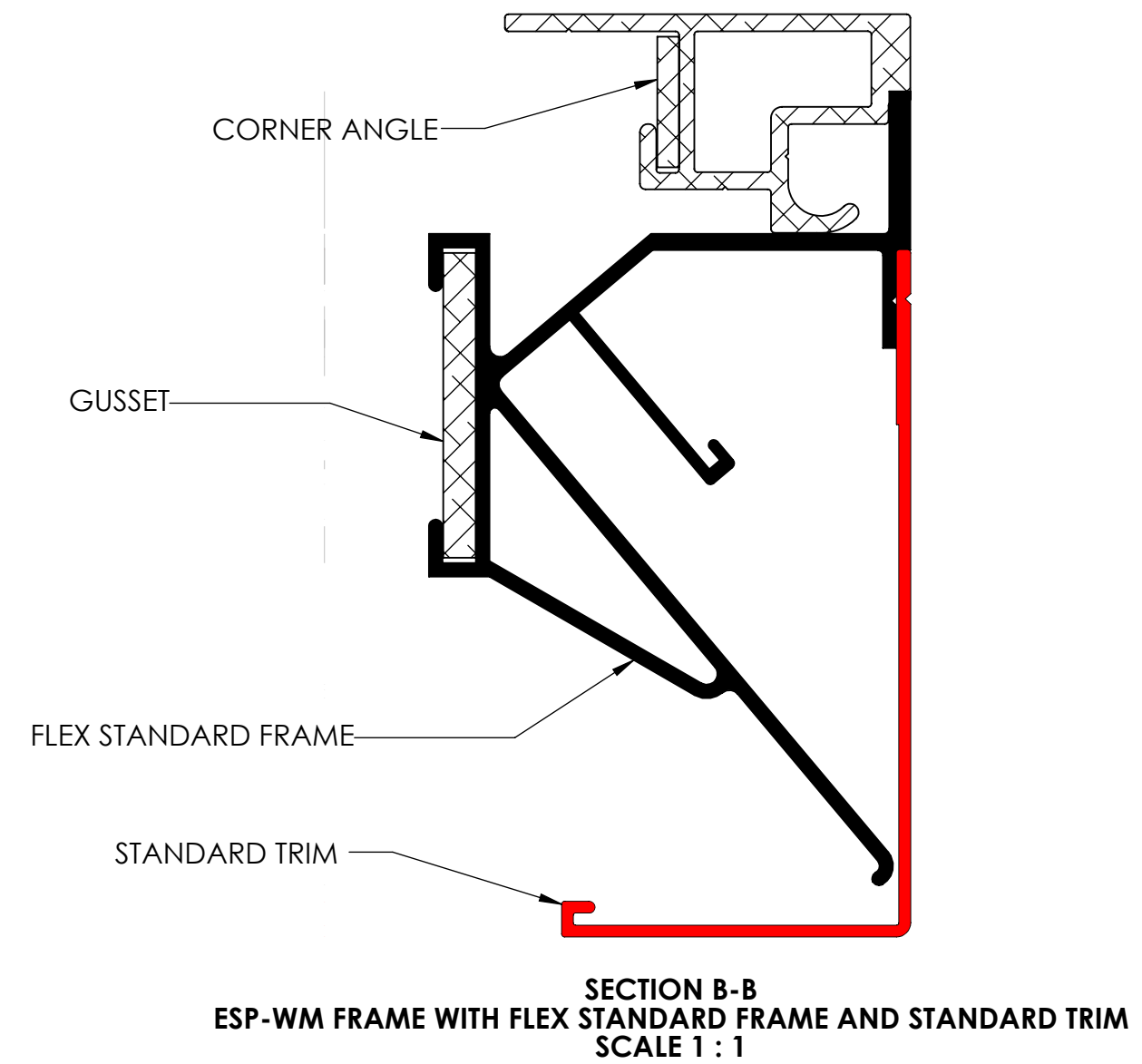
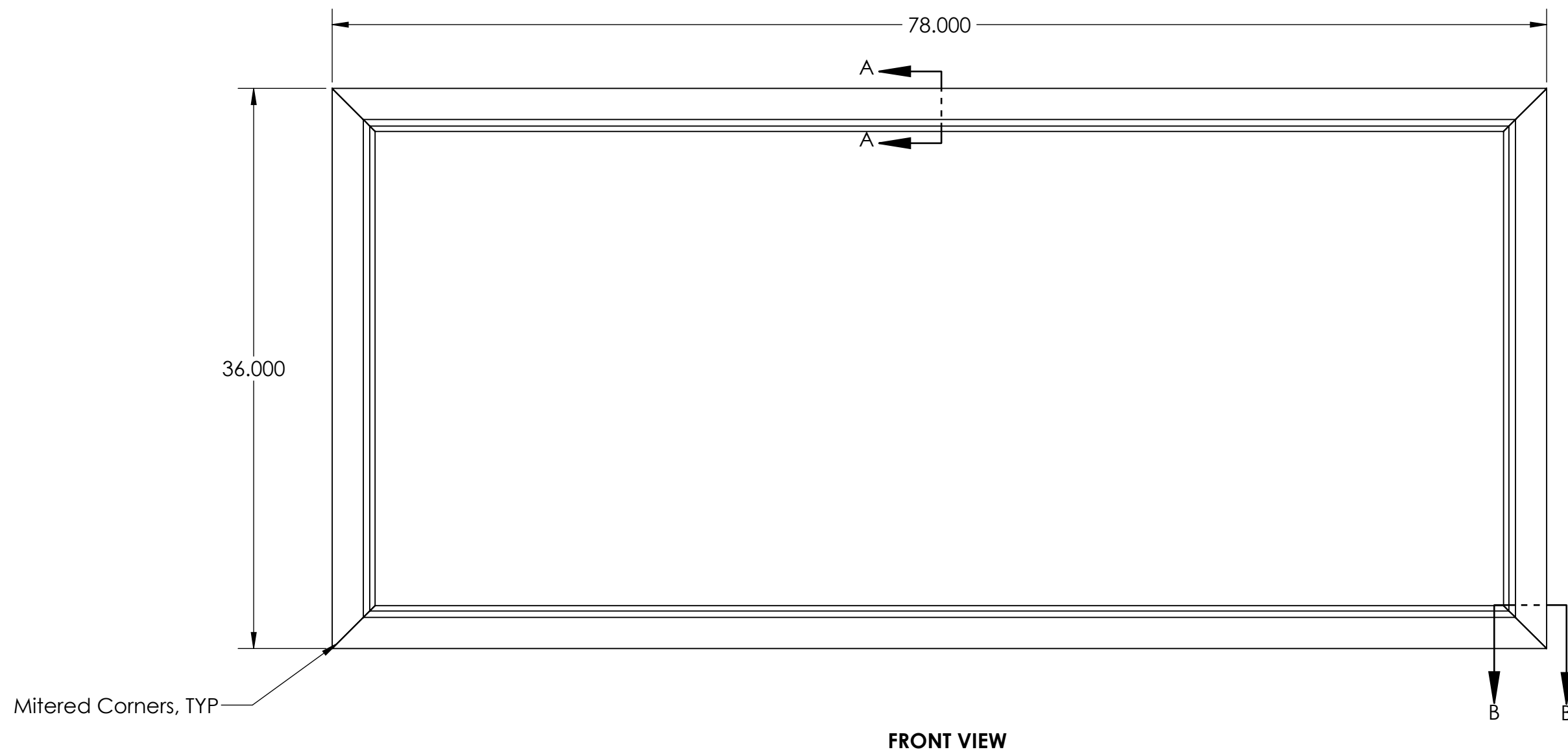

<b>EXCELLART SIGN PRODUCTS, LLC.</b> 1654 S. LONE ELM RD. OLATHE, KS 66061 (800) 627-9044 SALES@EXCELLART.COM WWW.EXCELLART.COM	UNLESS OTHERWISE SPECIFIED: DIMENSIONS ARE IN INCHES TOLERANCES FRAC = ± 1/32" XXX = ±0.03 XXXX = ±0.010 ANGULAR: MACH±1 BEND ±2	ASSEMBLY ID: <b>ESPH-WM-FLEXSTSF</b>
	<b>PROPRIETARY AND CONFIDENTIAL</b> THE INFORMATION CONTAINED IN THIS DRAWING IS THE SOLE PROPERTY OF EXCELLART SIGN PRODUCTS, LLC. ANY REPRODUCTION IN PART OR AS A WHOLE WITHOUT THE WRITTEN PERMISSION OF EXCELLART SIGN PRODUCTS, LLC IS PROHIBITED.	DESCRIPTION: <b>ESP-WM HINGED W. FLEX AND STANDARD TRIM</b>
	DRAWN BY: <b>EXCELLART</b>	APPROVED BY:
THE INFORMATION CONTAINED IN THIS DRAWING IS THE SOLE PROPERTY OF EXCELLART SIGN PRODUCTS, LLC. ANY REPRODUCTION IN PART OR AS A WHOLE WITHOUT THE WRITTEN PERMISSION OF EXCELLART SIGN PRODUCTS, LLC IS PROHIBITED.	SIZE <b>C</b>	Weight: <b>47.78</b> (lbs) Perimeter Length: <b>19</b> (ft)
	SCALE: 1:8	1/10/2024 SHEET 2 OF 3

4

3

2

1

A

A

4

3

2

1

BOM

ITEM NO.	PART NUMBER	DESCRIPTION	MATERIAL	QTY.
1	ESP1280290	ESP-WM HINGED FRAME	6063-T6	1
2	ESP1280425, ESP1280420	ESP-FLEX STANDARD AND HINGED FRAME	6063-T6	1
3	ESP1280430	ESP-STANDARD TRIM	6063-T6	1
4	ESP1280307	1 3/4" X 3" X 3" X 3/16" GUSSET	6063-T6	4
5	ESP1280289	2 X 2 X .125" ANGLE	6063-T6	4

NOTES:

- 1) ESP-WM KIT CONSISTS OF QTY (4) ESP-WM FRAME PIECES, QTY (4) CORNER ANGLES, QTY (3) ESP-FLEX STANDARD FRAME PIECES, QTY (1) ESP-FLEX HINGED FRAME PIECE, QTY (4) FLEX GUSSETS, AND QTY (4) STANDARD TRIM PIECES
- 2) ANGLES ARE USED TO GUIDE FRAME PIECES INTO POSITION
- 3) GUSSETS ARE USED TO GUIDE RETAINER PIECES INTO POSITION (IF APPLICABLE)
- 4) HINGED FRAME SECTION AND HINGED RETAINERS SHOWN TO BE ON TOP OF SIGN CABINET (IF APPLICABLE)
- 5) SELF DRILLING SCREWS / RIVETS / LOCK CYLINDERS ETC (BY OTHERS) TO SECURE RETAINERS AS NEEDED
- 6) ANGLES AND GUSSETS TYPICALLY WELDED TO FRAMING (BY OTHERS)
- 7) 6" - 8" CENTER TO CENTER SPACING RECOMMENDED FOR FLEX CLIPS
- 8) PIANO HINGES USED TO ALLOW IDS RETAINERS TO HINGE OPEN (IF APPLICABLE)
- 9) H1 / H1.5 RETAINERS ALLOW SECONDARY FACE TO BE MOUNTED BEHIND PRIMARY FACE
- 10) EXCELLART UL FILE NUMBER: E152309

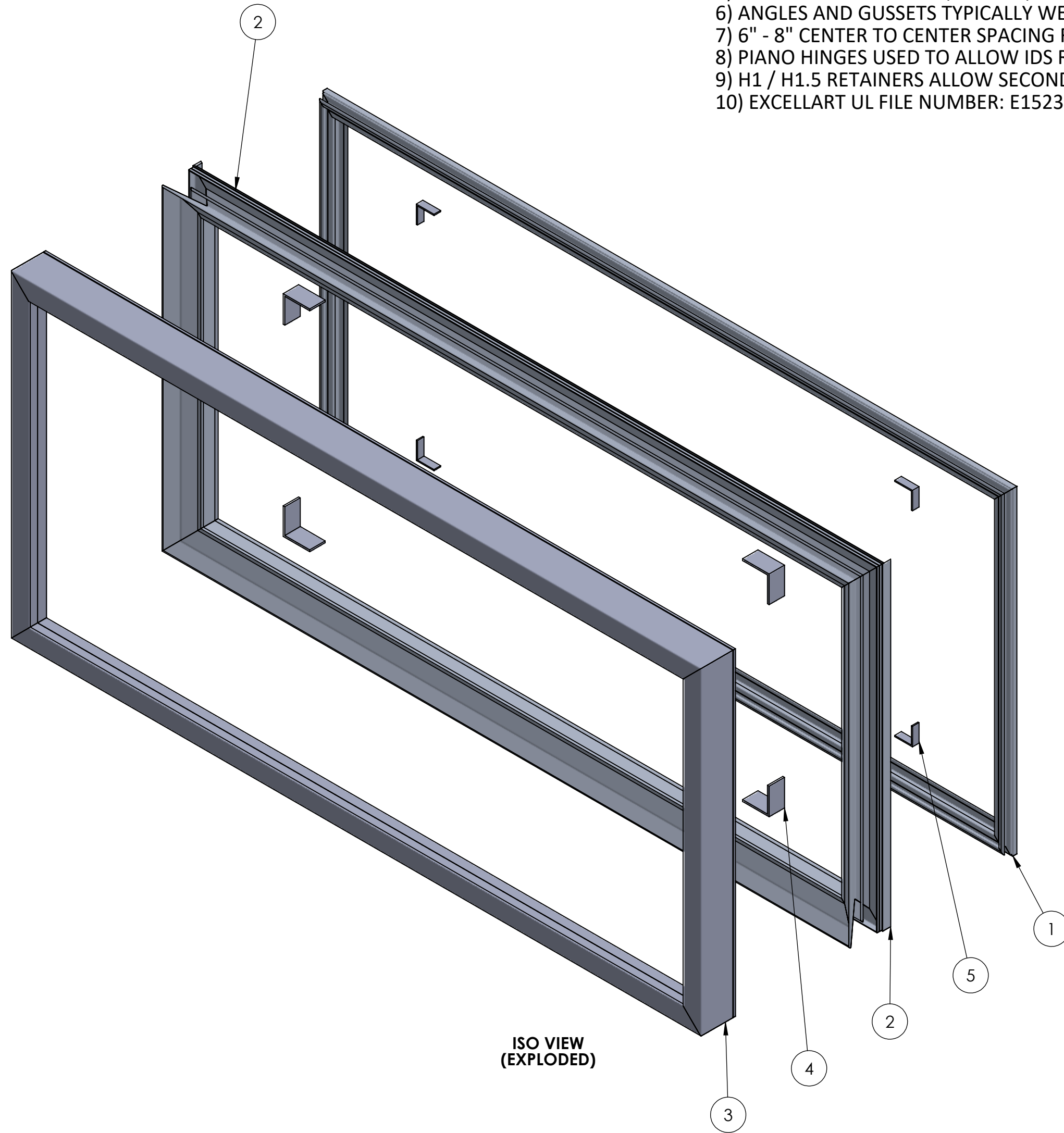

ISO VIEW (EXPLODED)

<b>EXCELLART SIGN PRODUCTS, LLC.</b> 1654 S. LONE ELM RD. OLATHE, KS 66061 (800) 627-9044 SALES@EXCELLART.COM WWW.EXCELLART.COM	UNLESS OTHERWISE SPECIFIED: DIMENSIONS ARE IN INCHES TOLERANCES: FRAC = ± 1/32" X.XX = ± 0.03 X.XXX = ± 0.010 ANGULAR: MACH ± 1° BEND ± 2°	ASSEMBLY ID: <b>ESPH-WM-FLEXSTSF</b>	
		DESCRIPTION: <b>ESP-WM HINGED W. FLEX AND STANDARD TRIM</b>	
<b>EXCELLART</b> <small>THE INFORMATION CONTAINED IN THIS DRAWING IS THE SOLE PROPERTY OF EXCELLART SIGN PRODUCTS, LLC. ANY REPRODUCTION IN PART OR AS A WHOLE WITHOUT THE WRITTEN PERMISSION OF EXCELLART SIGN PRODUCTS, LLC IS PROHIBITED.</small>	PROPRIETARY AND CONFIDENTIAL	DRAWN BY: <b>EXCELLART</b>	APPROVED BY:
	SIZE: <b>C</b>	Weight: <b>47.78</b> (lbs)	REV: -
	SCALE: 1:8	1/10/2024	SHEET 3 OF 3

4

3

2

1