

4

3

2

1

COVER

D

D

C

C

B

B

A

A

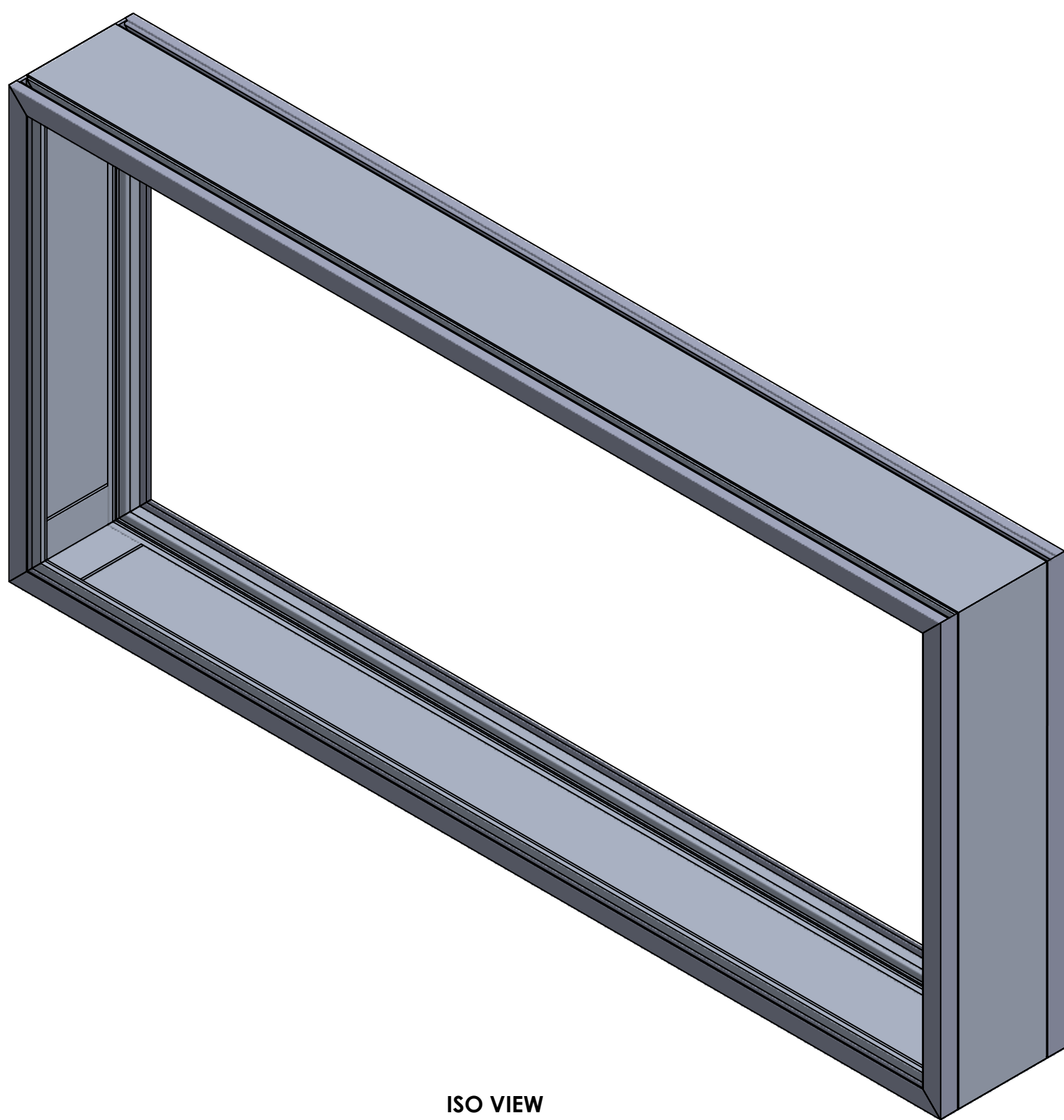

ISO VIEW

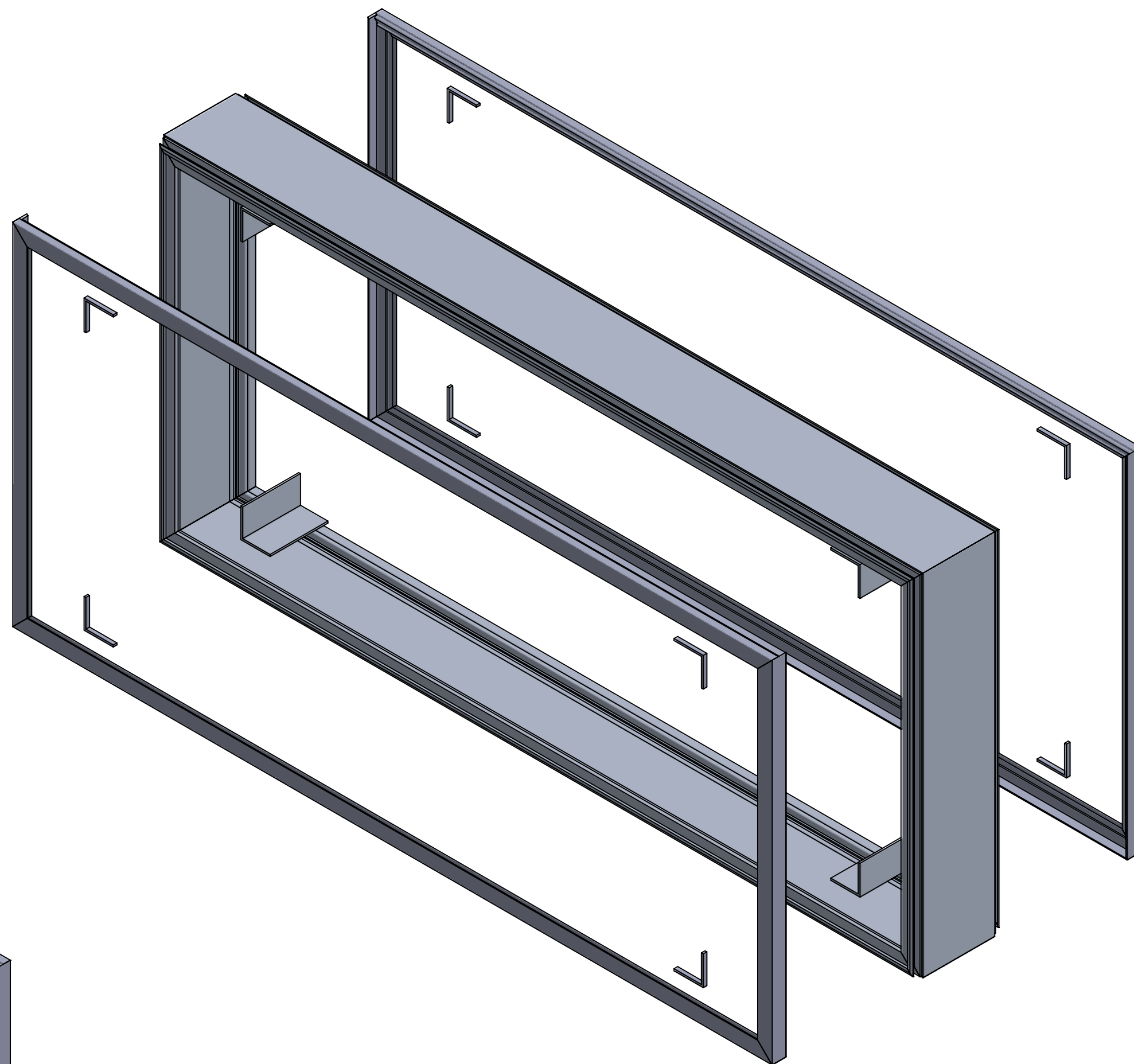

ISO VIEW (EXPLODED)

EXCELLART SIGN PRODUCTS, LLC.

1654 S. LONE ELM RD.
 OLATHE, KS 66061
 (800) 627-9044
 SALES@EXCELLART.COM
 WWW.EXCELLART.COM



UNLESS OTHERWISE SPECIFIED:
 DIMENSIONS ARE IN INCHES
 TOLERANCES:
 FRAC = ± 1/32"
 X.XX = ± 0.03
 X.XXX = ± 0.010
 ANGULAR: MACH ± 1 BEND ± 2

PROPRIETARY AND CONFIDENTIAL
 THE INFORMATION CONTAINED IN
 THIS DRAWING IS THE SOLE
 PROPERTY OF EXCELLART SIGN
 PRODUCTS, LLC. ANY
 REPRODUCTION IN PART OR AS A
 WHOLE WITHOUT THE WRITTEN
 PERMISSION OF EXCELLART SIGN
 PRODUCTS, LLC IS PROHIBITED.

ASSEMBLY ID:
ESP-DF-FDF

DESCRIPTION:
ESP-DF HINGED W. F RETAINER

DRAWN BY: EXCELLART APPROVED BY:

SIZE	Weight: 54.85 (lbs)	REV
C	Perimeter Length: 19 (ft)	-

SCALE: 1:8	1/8/2024	SHEET 1 OF 3
------------	----------	--------------

4

3

2

1

4

3

2

1

DIMS

D

D

C

C

B

B

A

A

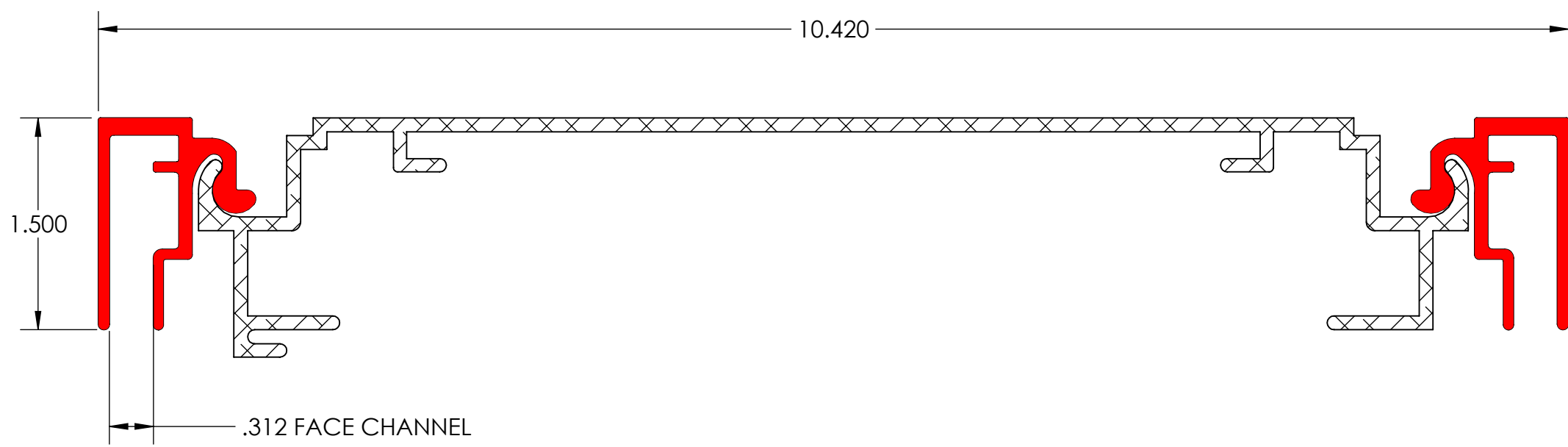
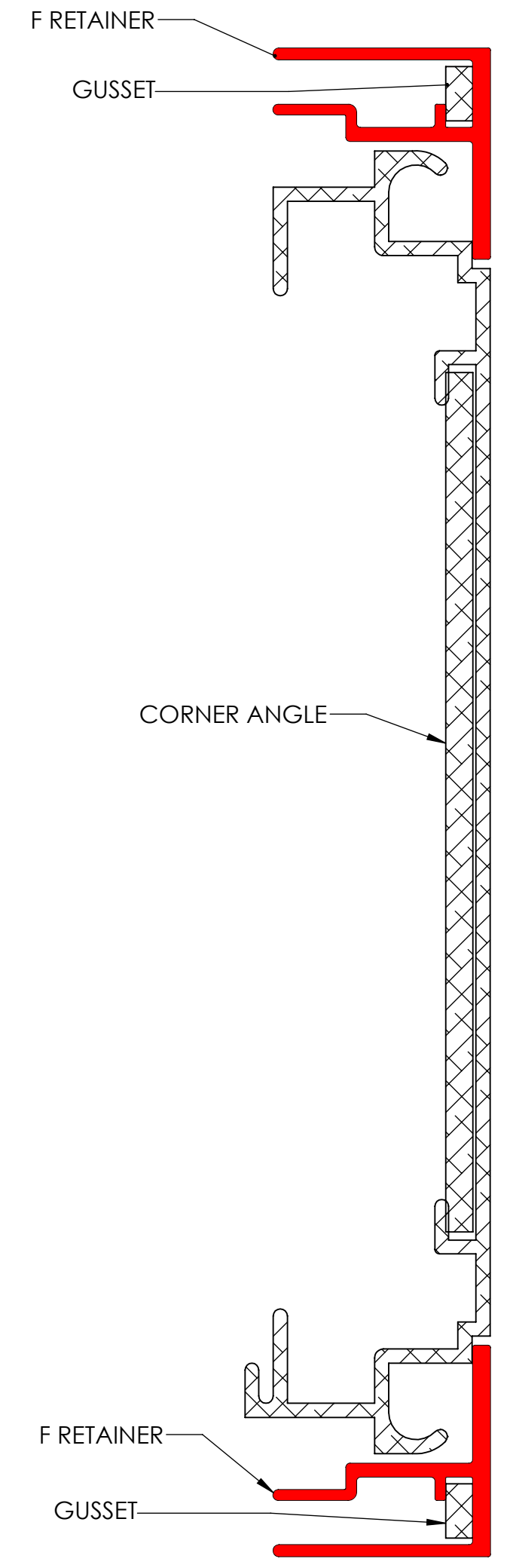
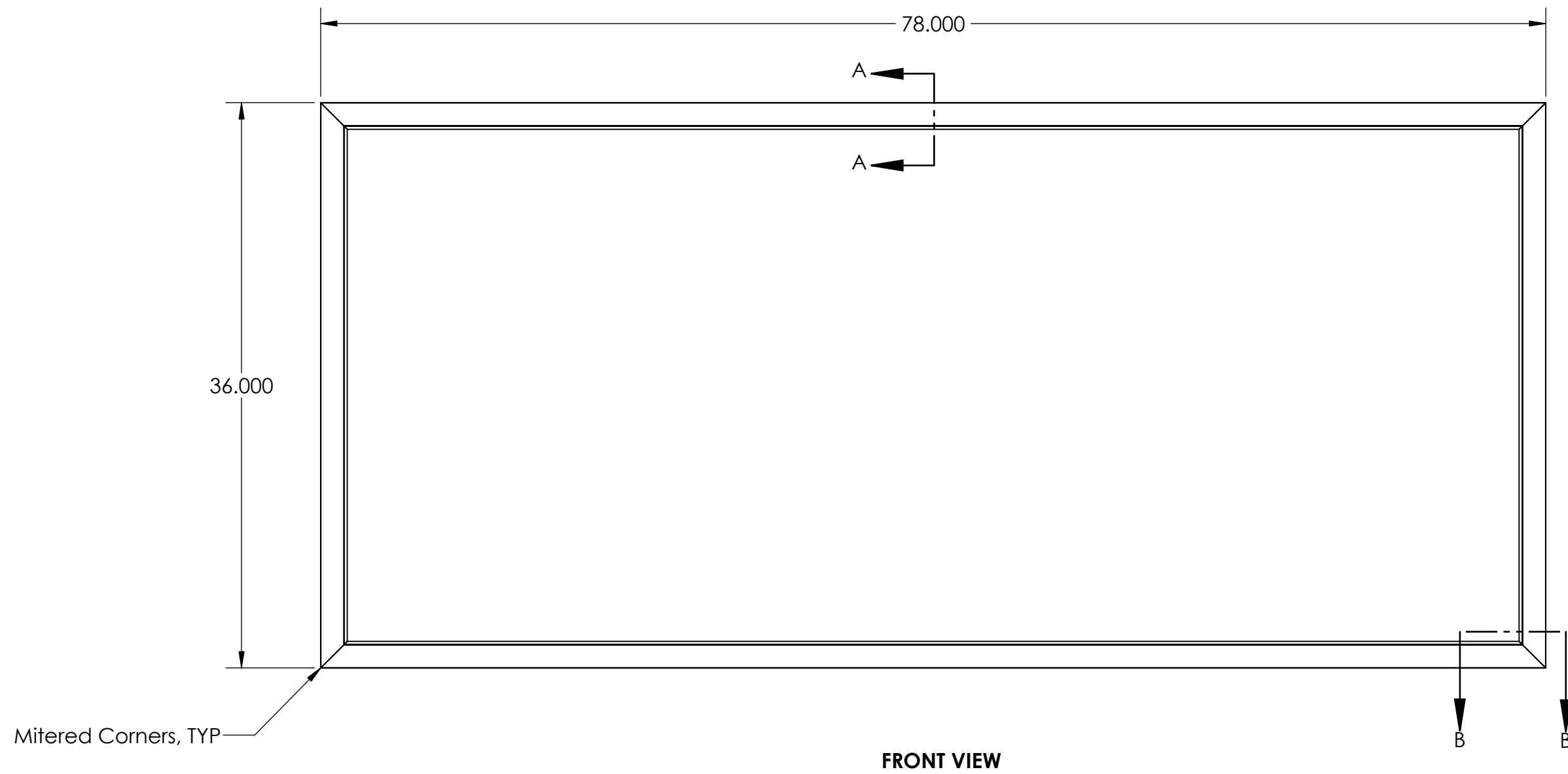

SECTION B-B
ESP-DF HINGED FRAME WITH ESP-F RETAINERS
SCALE 1 : 1

EXCELLART SIGN PRODUCTS, LLC. 1654 S. LONE ELM RD. OLATHE, KS 66061 (800) 627-9044 SALES@EXCELLART.COM WWW.EXCELLART.COM	UNLESS OTHERWISE SPECIFIED: DIMENSIONS ARE IN INCHES TOLERANCES FRAC = ± 1/32" XXX = ± 0.03 XXXX = ± 0.010 ANGULAR: MACH ± 1° BEND ± 2°	ASSEMBLY ID: ESPS-DF-FDF	
		DESCRIPTION: ESP-DF HINGED W. F RETAINER	
EXCELLART <small>THE INFORMATION CONTAINED IN THIS DRAWING IS THE SOLE PROPERTY OF EXCELLART SIGN PRODUCTS, LLC. ANY REPRODUCTION IN PART OR AS A WHOLE WITHOUT THE WRITTEN PERMISSION OF EXCELLART SIGN PRODUCTS, LLC IS PROHIBITED.</small>	PROPRIETARY AND CONFIDENTIAL	DRAWN BY: EXCELLART	APPROVED BY:
	SIZE C	Weight: 54.85 (lbs) Perimeter Length: 19 (ft)	REV -
	SCALE: 1:8	1/8/2024	SHEET 2 OF 3

4

3

2

1

BOM

ITEM NO.	PART NUMBER	DESCRIPTION	MATERIAL	QTY.
1	ESP1280465	ESP-DF HINGED FRAME	6063-T6	1
2	ESP1280302	ESP-F HINGED RETAINER	6063-T6	2
3	ESP1280301	ESP-F RETAINER	6063-T6	2
4	ESP1280139	5 15/16" X 3" X 3" X 3/16" ANGLE	6063-T6	4
5	ESP1280185	3/8" X 3" X 3" X 3/16" GUSSET	6063-T6	8

NOTES:

- 1) ESP-DF HINGED KIT CONSISTS OF QTY (3) ESP-DF FRAME PIECES, QTY (1) ESP-DF HINGED FRAME PIECE, QTY (4) CORNER ANGLES, QTY (6) ESP-F RETAINERS, QTY (2) ESP-F HINGED RETAINERS, AND QTY (8) RETAINER GUSSETS
- 2) ANGLES ARE USED TO GUIDE FRAME PIECES INTO POSITION
- 3) GUSSETS ARE USED TO GUIDE RETAINER PIECES INTO POSITION (IF APPLICABLE)
- 4) HINGED FRAME SECTION AND HINGED RETAINERS SHOWN TO BE ON TOP OF SIGN CABINET (IF APPLICABLE)
- 5) SELF DRILLING SCREWS / RIVETS / LOCK CYLINDERS ETC (BY OTHERS) TO SECURE RETAINERS AS NEEDED
- 6) ANGLES AND GUSSETS TYPICALLY WELDED TO FRAMING (BY OTHERS)
- 7) 6" - 8" CENTER TO CENTER SPACING RECOMMENDED FOR FLEX CLIPS
- 8) PIANO HINGES USED TO ALLOW IDS RETAINERS TO HINGE OPEN (IF APPLICABLE)
- 9) H1 / H1.5 RETAINERS ALLOW SECONDARY FACE TO BE MOUNTED BEHIND PRIMARY FACE
- 10) EXCELLART UL FILE NUMBER: E152309

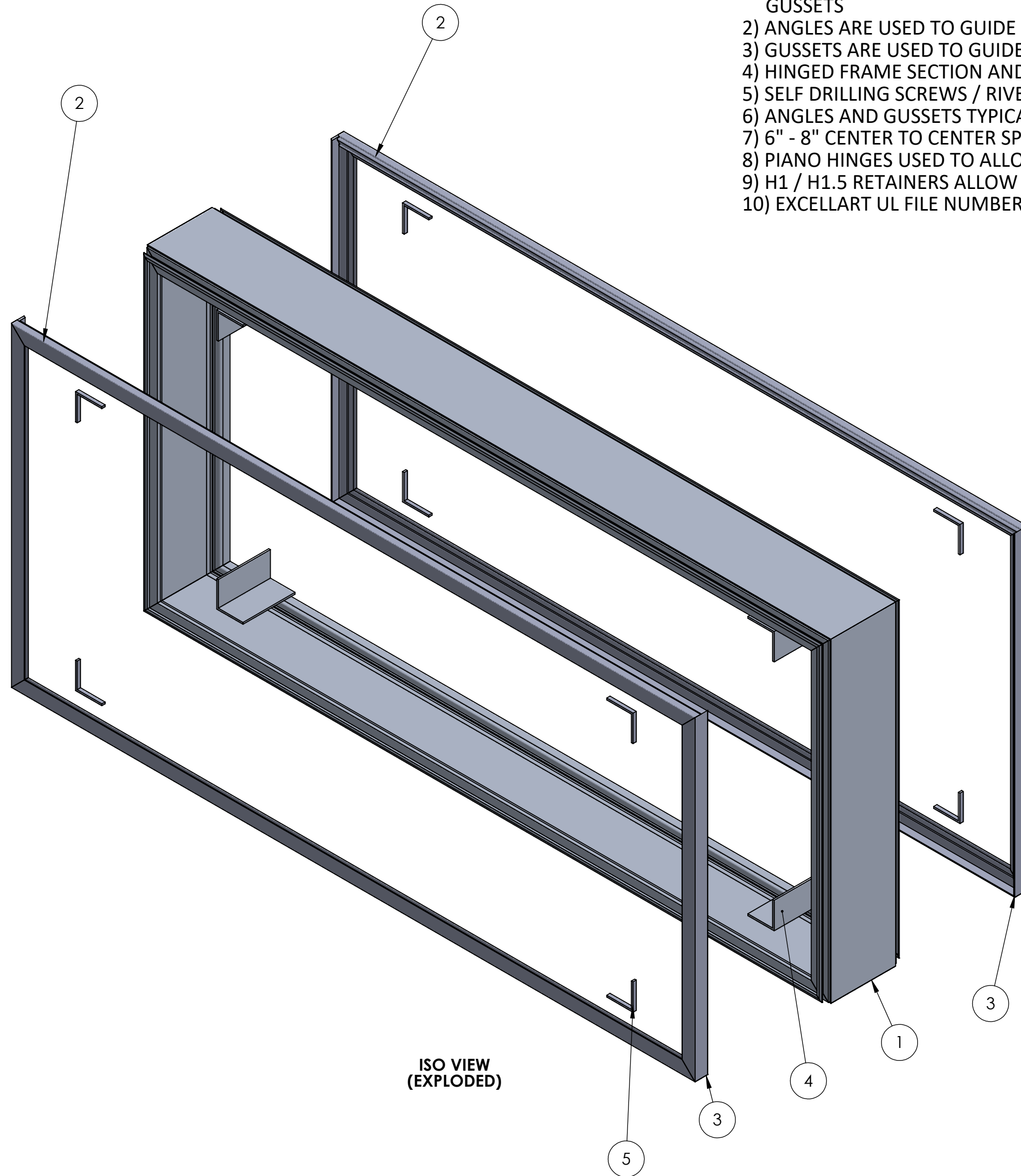

ISO VIEW (EXPLODED)

EXCELLART SIGN PRODUCTS, LLC. 1654 S. LONE ELM RD. OLATHE, KS 66061 (800) 627-9044 SALES@EXCELLART.COM WWW.EXCELLART.COM	UNLESS OTHERWISE SPECIFIED: DIMENSIONS ARE IN INCHES TOLERANCES: FRAC = ± 1/32" X.XX = ± 0.03 X.XXX = ± 0.010 ANGULAR: MACH ± 1° BEND ± 2°	ASSEMBLY ID: ESPS-DF-FDF	
		DESCRIPTION: ESP-DF HINGED W. F RETAINER	
EXCELLART <small>THE INFORMATION CONTAINED IN THIS DRAWING IS THE SOLE PROPERTY OF EXCELLART SIGN PRODUCTS, LLC. ANY REPRODUCTION IN PART OR AS A WHOLE WITHOUT THE WRITTEN PERMISSION OF EXCELLART SIGN PRODUCTS, LLC IS PROHIBITED.</small>	DRAWN BY: EXCELLART	APPROVED BY:	
	SIZE: C	Weight: 54.85 (lbs)	REV: -
	Perimeter Length: 19 (ft)		
SCALE: 1:8		1/8/2024	SHEET 3 OF 3

4

3

2

1