

2

1

NOTES:

- 1) TYP WALL THICKNESS = 0.093" EXCEPT AS NOTED
- 2) 1' LENGTH SHOWN FOR WEIGHT CALCULATIONS

B

B

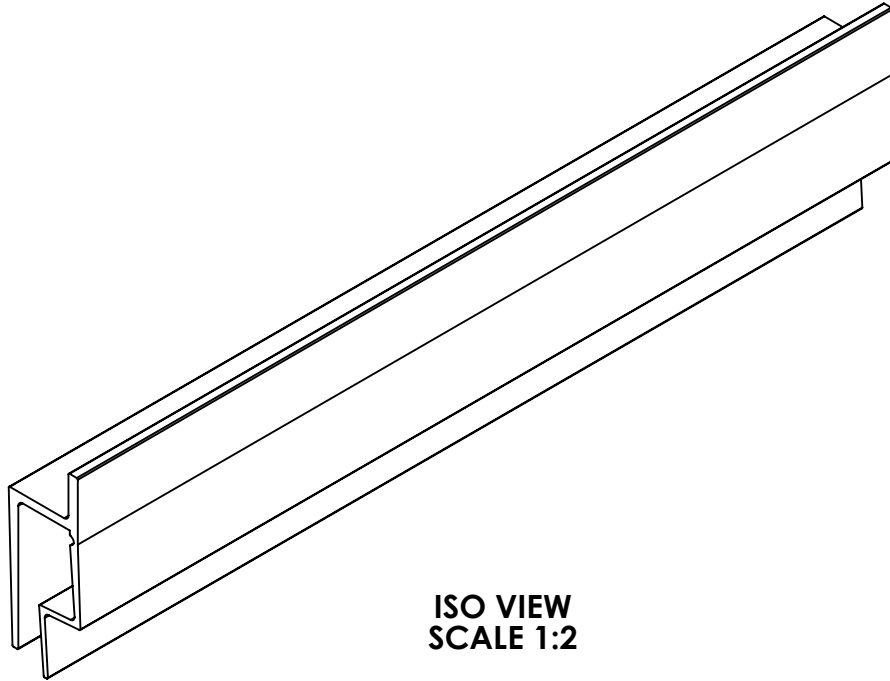

ISO VIEW  
SCALE 1:2

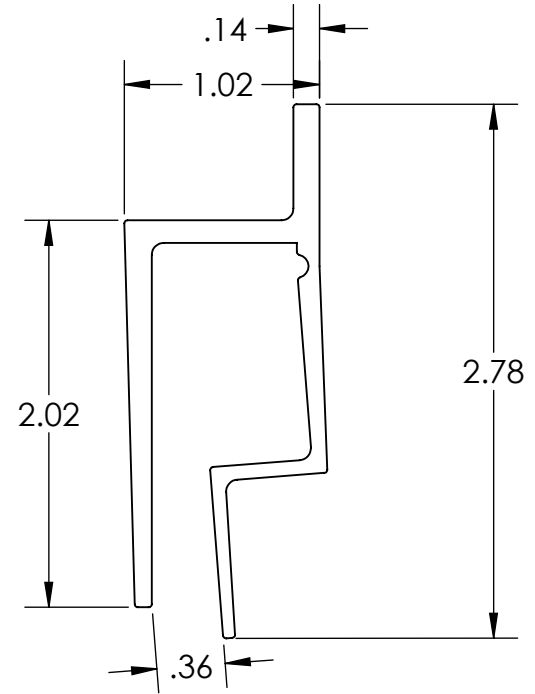

PROFILE VIEW

A

A

<p><b>EXCELLART SIGN PRODUCTS, LLC.</b></p> <p>1654 S. LONE ELM RD. OLATHE, KS 66061</p> <p>(800) 627-9044 SALES@EXCELLART.COM WWW.EXCELLART.COM</p> 	<p>UNLESS OTHERWISE SPECIFIED: DIMENSIONS ARE IN INCHES <u>TOLERANCES</u> FRAC = ±1/32" X.XX = ±0.03 X.XXX = ±0.010 ANGULAR: MACH±1 BEND ±2</p>	<p>TITLE: <b>ESP-ZF 2 RETAINER</b></p>	
	<p>PROPRIETARY AND CONFIDENTIAL</p> <p>THE INFORMATION CONTAINED IN THIS DRAWING IS THE SOLE PROPERTY OF EXCELLART SIGN PRODUCTS, LLC. ANY REPRODUCTION IN PART OR AS A WHOLE WITHOUT THE WRITTEN PERMISSION OF EXCELLART SIGN PRODUCTS, LLC IS PROHIBITED.</p>	<p>DESCRIPTION: <b>ESP1280164</b></p> <p>MATERIAL: <b>6063-T6</b></p>	
	<p>DRAWN BY: <b>EXCELLART</b></p>	<p>APPROVED BY:</p>	
	<p>SIZE <b>A</b></p>	<p>Weight: <b>0.74</b> pound(s) per foot</p>	<p>REV -</p>
	<p>SCALE: 1:1</p>	<p>2/19/2024</p>	<p>SHEET 1 OF 1</p>

2

1