

2

1

NOTES:

- 1) TYP WALL THICKNESS = 0.098" EXCEPT AS NOTED
- 2) 1' LENGTH SHOWN FOR WEIGHT CALCULATIONS

B

B

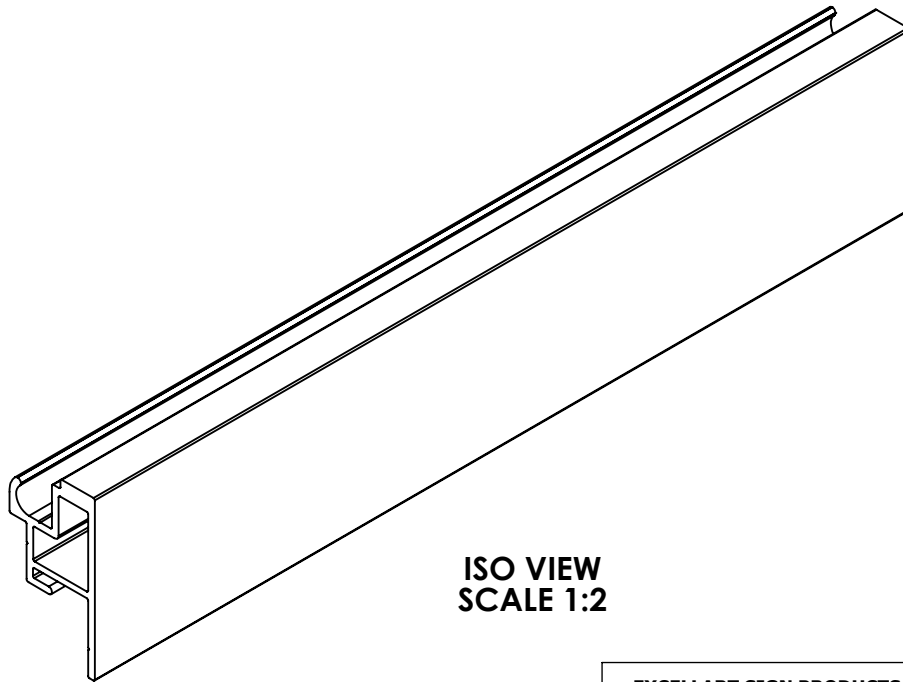

ISO VIEW  
SCALE 1:2

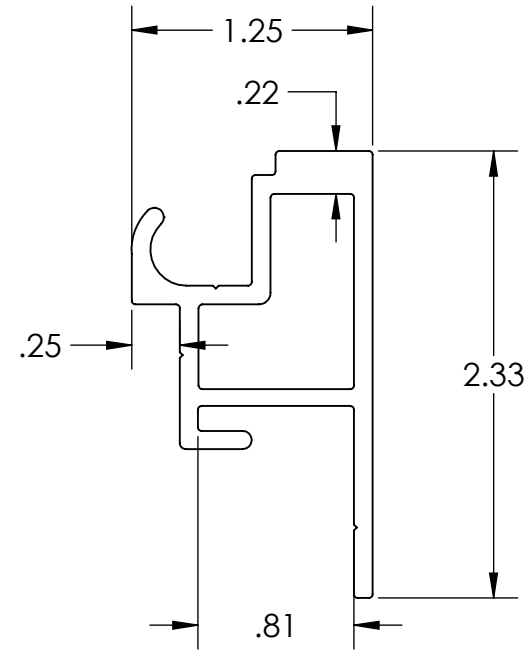

PROFILE VIEW

A

A

<b>EXCELLART SIGN PRODUCTS, LLC.</b> 1654 S. LONE ELM RD. OLATHE, KS 66061 (800) 627-9044 SALES@EXCELLART.COM WWW.EXCELLART.COM 	UNLESS OTHERWISE SPECIFIED: DIMENSIONS ARE IN INCHES <u>TOLERANCES</u> FRAC = ±1/32" X.XX = ±0.03 X.XXX = ±0.010 ANGULAR: MACH±1 BEND ±2	TITLE: <b>ESP-WM FRAME</b>	
	<b>PROPRIETARY AND CONFIDENTIAL</b> THE INFORMATION CONTAINED IN THIS DRAWING IS THE SOLE PROPERTY OF EXCELLART SIGN PRODUCTS, LLC. ANY REPRODUCTION IN PART OR AS A WHOLE WITHOUT THE WRITTEN PERMISSION OF EXCELLART SIGN PRODUCTS, LLC IS PROHIBITED.	DESCRIPTION: <b>ESP1280290</b>	
	DRAWN BY: <b>EXCELLART</b>	APPROVED BY:	
SIZE <b>A</b>	Weight: <b>0.78</b> pound(s) per foot	SCALE: 1:1	REV -
	2/19/2024	SHEET 1 OF 1	

2

1