

2

1

NOTES:

- 1) TYP WALL THICKNESS = 0.093" EXCEPT AS NOTED
- 2) 1' LENGTH SHOWN FOR WEIGHT CALCULATIONS

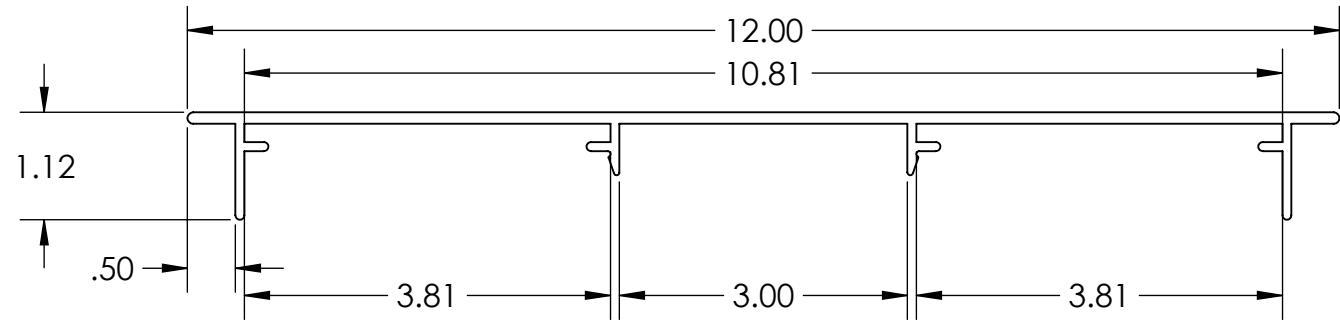

PROFILE VIEW

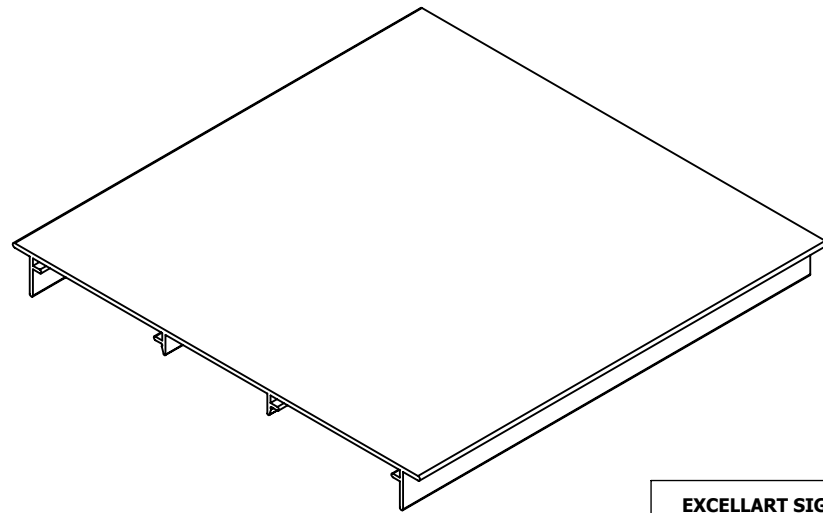

ISO VIEW
SCALE 1:4

EXCELLART SIGN PRODUCTS, LLC.

1654 S. LONE ELM RD.
OLATHE, KS 66061

(800) 627-9044
SALES@EXCELLART.COM
WWW.EXCELLART.COM



UNLESS OTHERWISE SPECIFIED:

DIMENSIONS ARE IN INCHES
TOLERANCES
 FRAC = ±1/32"
 X.XX = ±0.03
 X.XXX = ±0.010
 ANGULAR: MACH±1 BEND ±2

PROPRIETARY AND CONFIDENTIAL

THE INFORMATION CONTAINED IN THIS DRAWING IS THE SOLE PROPERTY OF EXCELLART SIGN PRODUCTS, LLC. ANY REPRODUCTION IN PART OR AS A WHOLE WITHOUT THE WRITTEN PERMISSION OF EXCELLART SIGN PRODUCTS, LLC IS PROHIBITED.

TITLE:
ESP-IDS 12 FRAME

DESCRIPTION:
ESP1280905

MATERIAL:
6063-T6

DRAWN BY:
EXCELLART

APPROVED BY:

SIZE	Weight: 2.12 pound(s) per foot	REV
A		-

SCALE: 1:2	2/19/2024	SHEET 1 OF 1
------------	-----------	--------------

2

1