

2

1

NOTES:

- 1) TYP WALL THICKNESS = 0.093" EXCEPT AS NOTED
- 2) 1' LENGTH SHOWN FOR WEIGHT CALCULATIONS

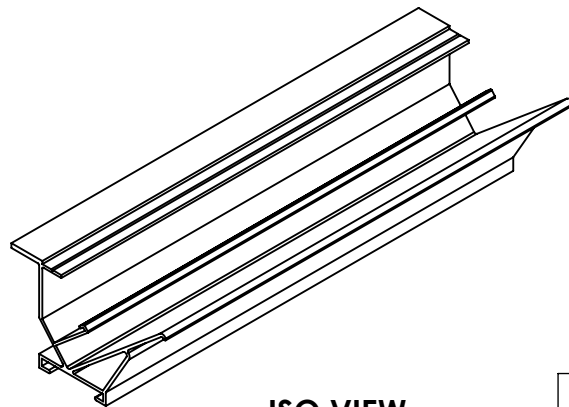

ISO VIEW
SCALE 1:4

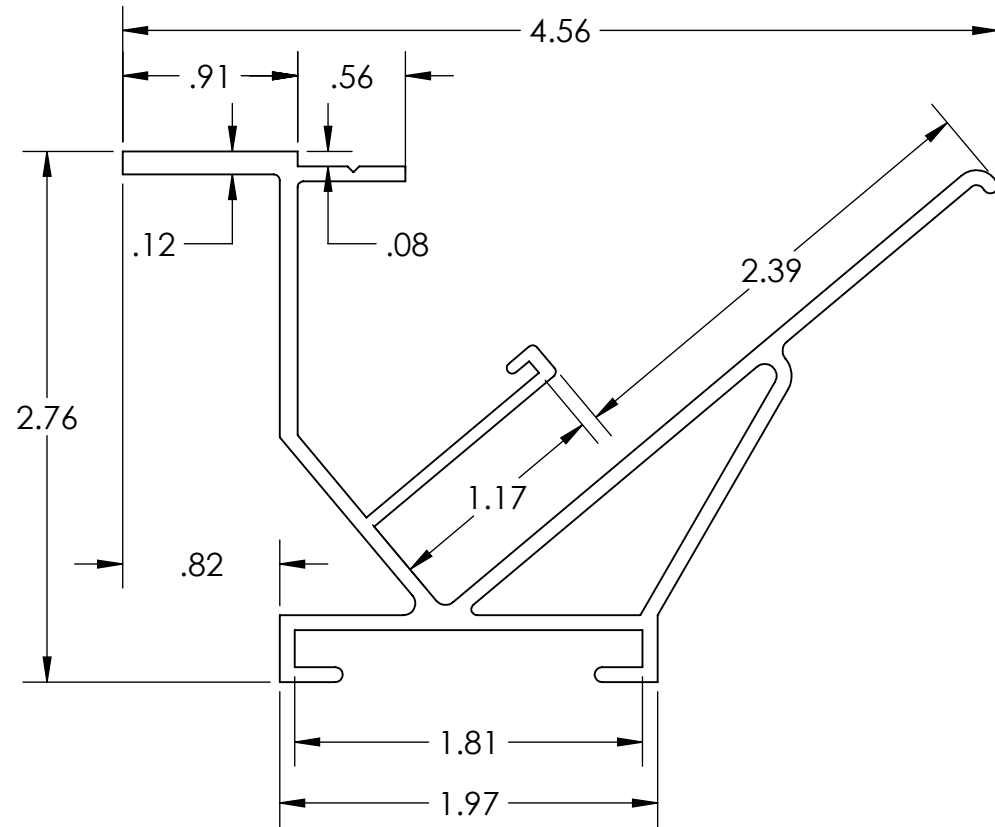

PROFILE VIEW

EXCELLART SIGN PRODUCTS, LLC. 1654 S. LONE ELM RD. OLATHE, KS 66061 (800) 627-9044 SALES@EXCELLART.COM WWW.EXCELLART.COM 	UNLESS OTHERWISE SPECIFIED: DIMENSIONS ARE IN INCHES <u>TOLERANCES</u> FRAC = ±1/32" X.XX = ±0.03 X.XXX = ±0.010 ANGULAR: MACH±1 BEND ±2	TITLE: ESP-FLEX STANDARD FRAME	
	PROPRIETARY AND CONFIDENTIAL THE INFORMATION CONTAINED IN THIS DRAWING IS THE SOLE PROPERTY OF EXCELLART SIGN PRODUCTS, LLC. ANY REPRODUCTION IN PART OR AS A WHOLE WITHOUT THE WRITTEN PERMISSION OF EXCELLART SIGN PRODUCTS, LLC IS PROHIBITED.	DESCRIPTION: ESP1280425	
	DRAWN BY: EXCELLART	APPROVED BY:	
SIZE A	Weight: 1.31 pound(s) per foot	REV -	
SCALE: 1:1	2/19/2024	SHEET 1 OF 1	

2

1

B

B

A

A