

2

1

NOTES:

- 1) TYP WALL THICKNESS = 0.07" EXCEPT AS NOTED
- 2) 1' LENGTH SHOWN FOR WEIGHT CALCULATIONS

B

B

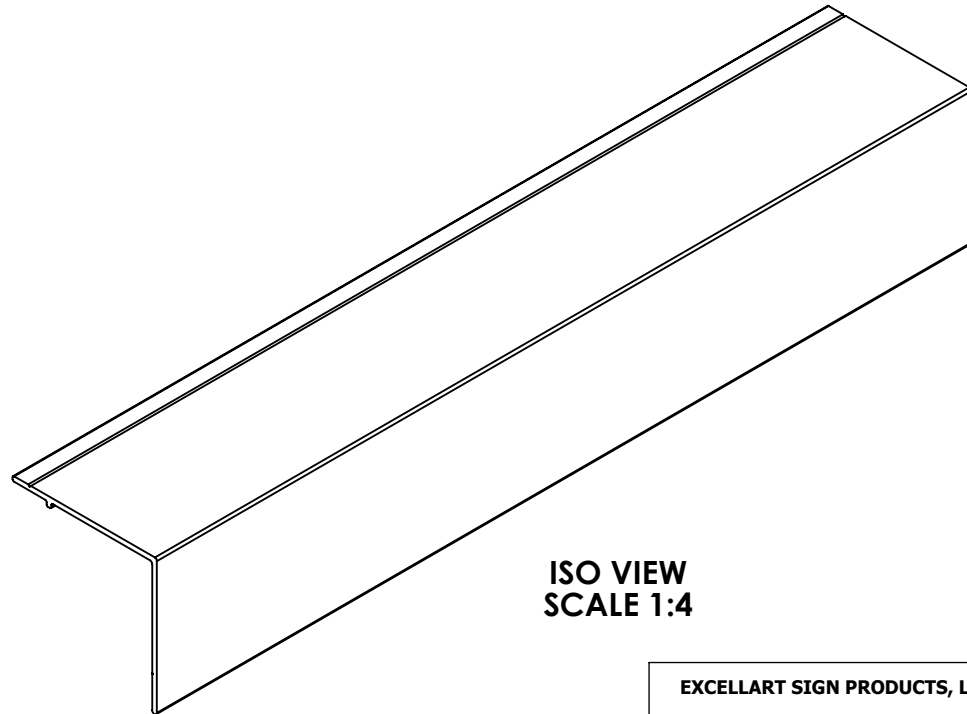

ISO VIEW
SCALE 1:4

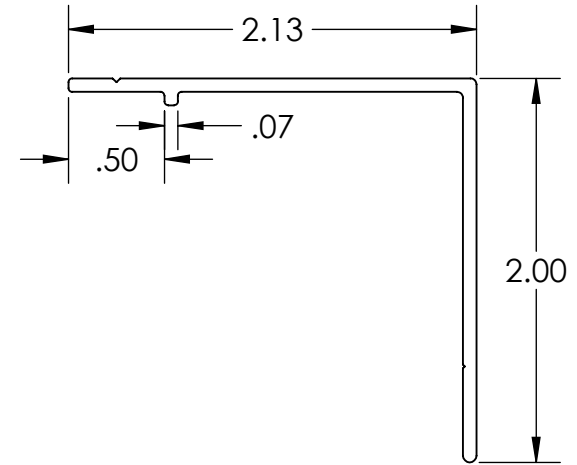

PROFILE VIEW

A

A

<p>EXCELLART SIGN PRODUCTS, LLC.</p> <p>1654 S. LONE ELM RD. OLATHE, KS 66061</p> <p>(800) 627-9044 SALES@EXCELLART.COM WWW.EXCELLART.COM</p> 	<p>UNLESS OTHERWISE SPECIFIED: DIMENSIONS ARE IN INCHES <u>TOLERANCES</u> FRAC = ±1/32" X.XX = ±0.03 X.XXX = ±0.010 ANGULAR: MACH±1 BEND ±2</p>	<p>TITLE: ESP-FLEX RETRO TRIM</p>		
	<p>PROPRIETARY AND CONFIDENTIAL</p> <p>THE INFORMATION CONTAINED IN THIS DRAWING IS THE SOLE PROPERTY OF EXCELLART SIGN PRODUCTS, LLC. ANY REPRODUCTION IN PART OR AS A WHOLE WITHOUT THE WRITTEN PERMISSION OF EXCELLART SIGN PRODUCTS, LLC IS PROHIBITED.</p>	<p>DESCRIPTION: ESP1280504</p>		
	<p>SIZE A</p>	<p>Weight: 0.34 pound(s) per foot</p>	<p>MATERIAL: 6063-T6</p>	
	<p>SCALE: 1:1</p>	<p>2/21/2024</p>	<p>DRAWN BY: EXCELLART</p>	<p>APPROVED BY:</p>

2

1