

2

1

NOTES:

- 1) TYP WALL THICKNESS = 0.110" EXCEPT AS NOTED
- 2) 1' LENGTH SHOWN FOR WEIGHT CALCULATIONS
- 3) PART COMES IN 2" LENGTHS (ALSO AVAILABLE IN 12' LENGTHS)

B

B

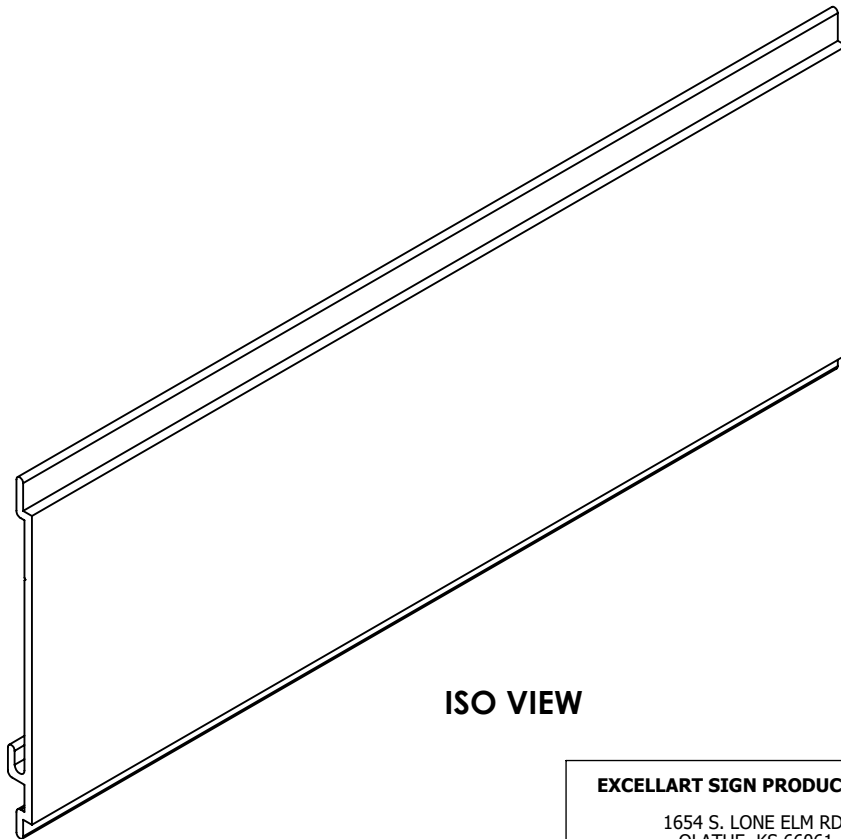

ISO VIEW

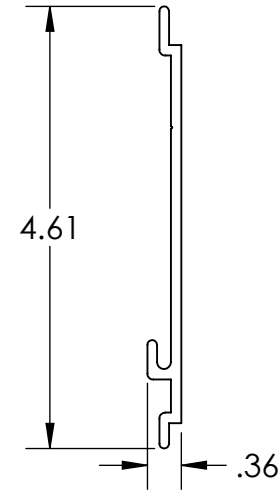

PROFILE VIEW

A

A

<p><b>EXCELLART SIGN PRODUCTS, LLC.</b></p> <p>1654 S. LONE ELM RD. OLATHE, KS 66061</p> <p>(800) 627-9044 SALES@EXCELLART.COM WWW.EXCELLART.COM</p> 	<p>UNLESS OTHERWISE SPECIFIED:</p> <p>DIMENSIONS ARE IN INCHES</p> <p><u>TOLERANCES</u></p> <p>FRAC = ±1/32"</p> <p>X.XX = ±0.03</p> <p>X.XXX = ±0.010</p> <p>ANGULAR: MACH±1 BEND ±2</p>	<p>TITLE: <b>ESP-CLRW MOUNTING BRACKET</b></p>	
	<p><b>PROPRIETARY AND CONFIDENTIAL</b></p> <p>THE INFORMATION CONTAINED IN THIS DRAWING IS THE SOLE PROPERTY OF EXCELLART SIGN PRODUCTS, LLC. ANY REPRODUCTION IN PART OR AS A WHOLE WITHOUT THE WRITTEN PERMISSION OF EXCELLART SIGN PRODUCTS, LLC IS PROHIBITED.</p>	<p>DESCRIPTION: <b>ESP1401008</b></p> <p>MATERIAL: <b>6063-T6</b></p>	
	<p>DRAWN BY: <b>EXCELLART</b></p>	<p>APPROVED BY:</p>	
	<p>SIZE <b>A</b></p>	<p>Weight: <b>0.68</b> pound(s) per foot</p>	<p>REV -</p>
	<p>SCALE: 1:2</p>	<p>2/19/2024</p>	<p>SHEET 1 OF 1</p>

2

1