

2

1

NOTES:

- 1) TYP WALL THICKNESS = 0.12" EXCEPT AS NOTED
- 2) 1' LENGTH SHOWN FOR WEIGHT CALCULATIONS

B

B

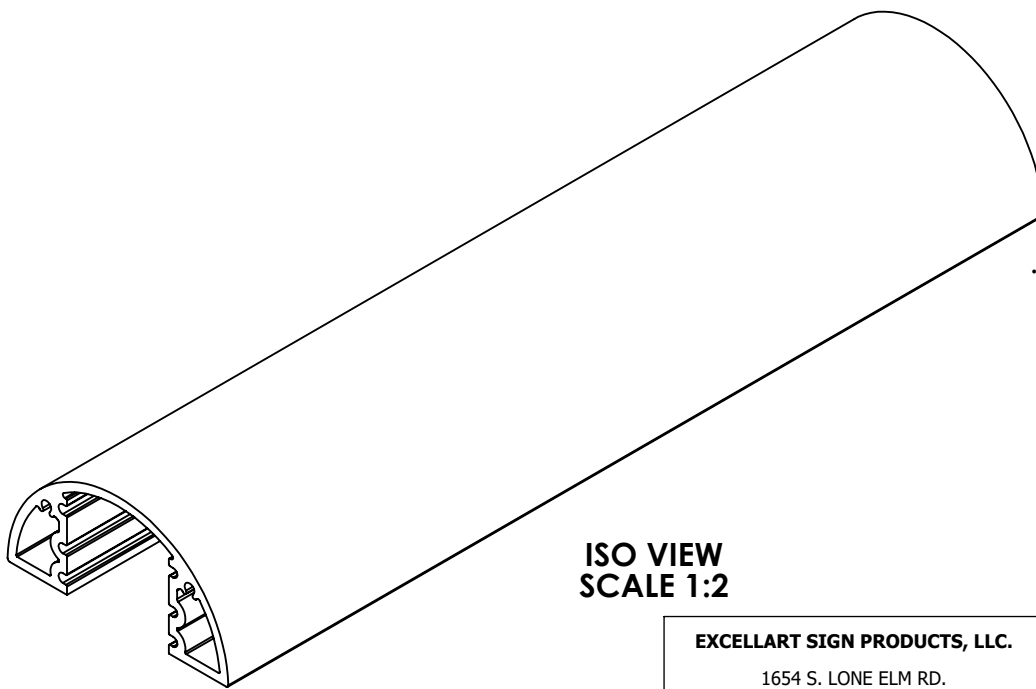

ISO VIEW  
SCALE 1:2

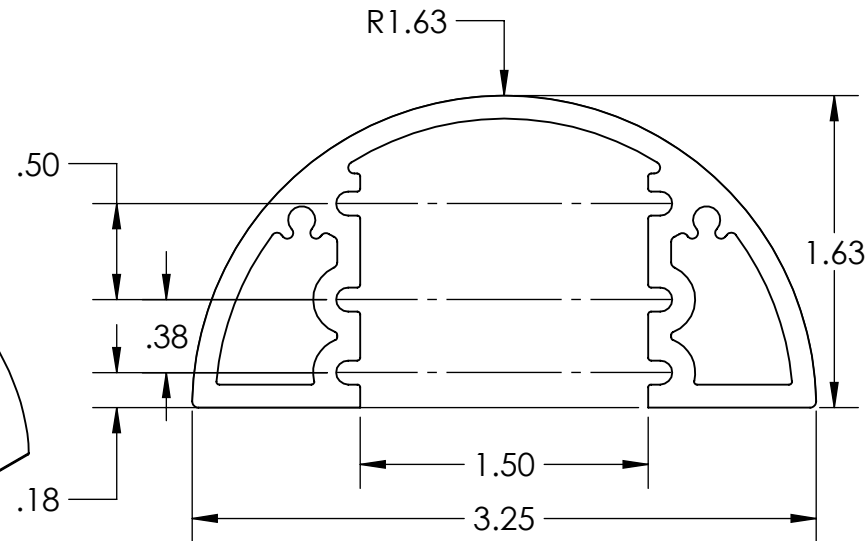

PROFILE VIEW

A

A

EXCELLART SIGN PRODUCTS, LLC.

1654 S. LONE ELM RD.  
OLATHE, KS 66061

(800) 627-9044  
SALES@EXCELLART.COM  
WWW.EXCELLART.COM



UNLESS OTHERWISE SPECIFIED:

DIMENSIONS ARE IN INCHES  
TOLERANCES  
FRAC = ±1/32"  
X.XX = ±0.03  
X.XXX = ±0.010  
ANGULAR: MACH±1 BEND ±2

PROPRIETARY AND CONFIDENTIAL

THE INFORMATION CONTAINED IN THIS DRAWING IS THE SOLE PROPERTY OF EXCELLART SIGN PRODUCTS, LLC. ANY REPRODUCTION IN PART OR AS A WHOLE WITHOUT THE WRITTEN PERMISSION OF EXCELLART SIGN PRODUCTS, LLC IS PROHIBITED.

TITLE:  
ESP-3.25 RADIUS POST

DESCRIPTION:  
ESP1380301

MATERIAL:  
6063-T6

DRAWN BY:  
EXCELLART

APPROVED BY:

SIZE  
**A** Weight: 1.35  
pound(s) per foot

REV  
-

SCALE: 1:1 | 2/19/2024 | SHEET 1 OF 1

2

1