

2

1

NOTES:

- 1) TYP WALL THICKNESS = 0.093" EXCEPT AS NOTED
- 2) 1' LENGTH SHOWN FOR WEIGHT CALCULATION

B

B

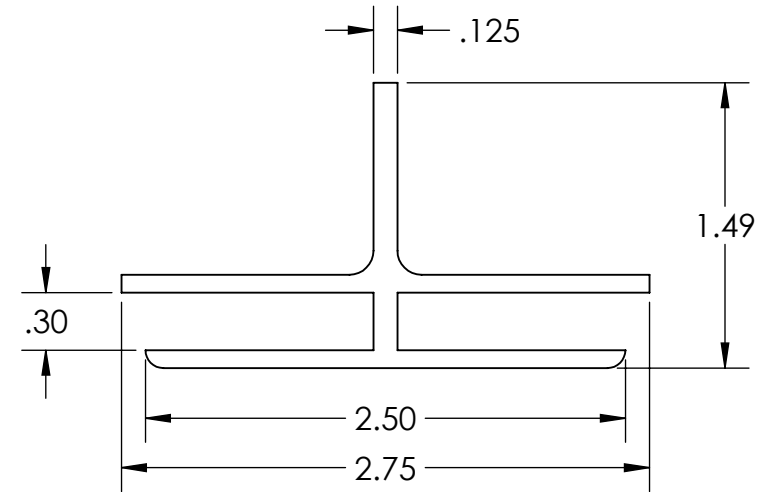
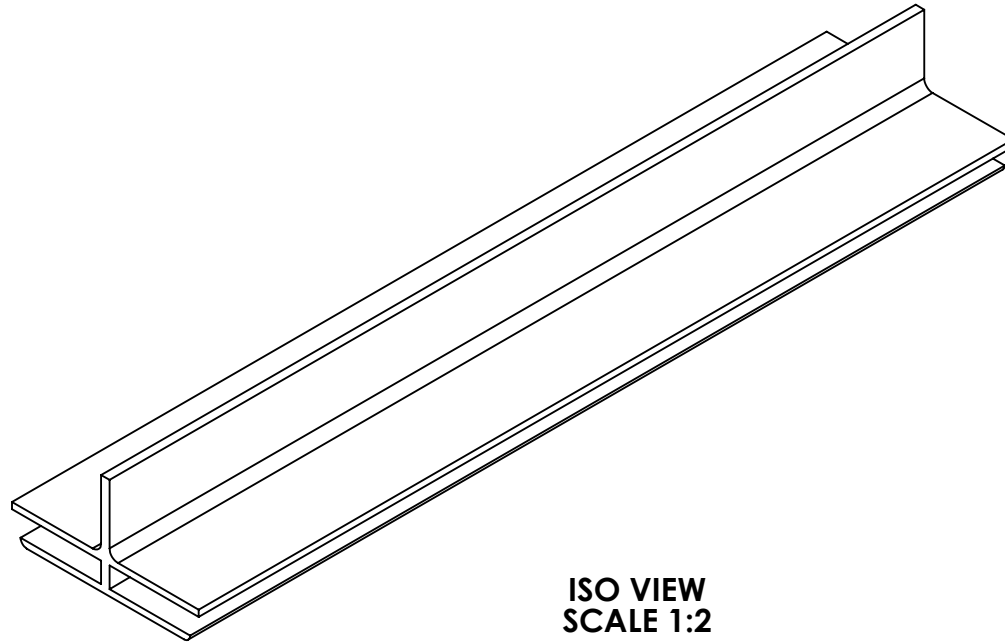

PROFILE VIEW

A

A

<p>EXCELLART SIGN PRODUCTS, LLC.</p> <p>1654 S. LONE ELM RD. OLATHE, KS 66061</p> <p>(800) 627-9044 SALES@EXCELLART.COM WWW.EXCELLART.COM</p> 	<p>UNLESS OTHERWISE SPECIFIED:</p> <p>DIMENSIONS ARE IN INCHES</p> <p><u>TOLERANCES</u></p> <p>FRAC = ±1/32"</p> <p>X.XX = ±0.03</p> <p>X.XXX = ±0.010</p> <p>ANGULAR: MACH±1 BEND ±2</p>		<p>TITLE: ESP-2.5 DIVIDER BAR</p>	
	<p>PROPRIETARY AND CONFIDENTIAL</p> <p>THE INFORMATION CONTAINED IN THIS DRAWING IS THE SOLE PROPERTY OF EXCELLART SIGN PRODUCTS, LLC. ANY REPRODUCTION IN PART OR AS A WHOLE WITHOUT THE WRITTEN PERMISSION OF EXCELLART SIGN PRODUCTS, LLC IS PROHIBITED.</p>		<p>DESCRIPTION: ESP1280167</p>	
	<p>SCALE: 1:1</p>		<p>MATERIAL: 6063-T6</p>	
	<p>DATE: 2/21/2024</p>		<p>APPROVED BY:</p>	
<p>SIZE A</p>		<p>Weight: 0.77 pound(s) per foot</p>		<p>REV -</p>
<p>SHEET 1 OF 1</p>		<p>2/21/2024</p>		

2

1